

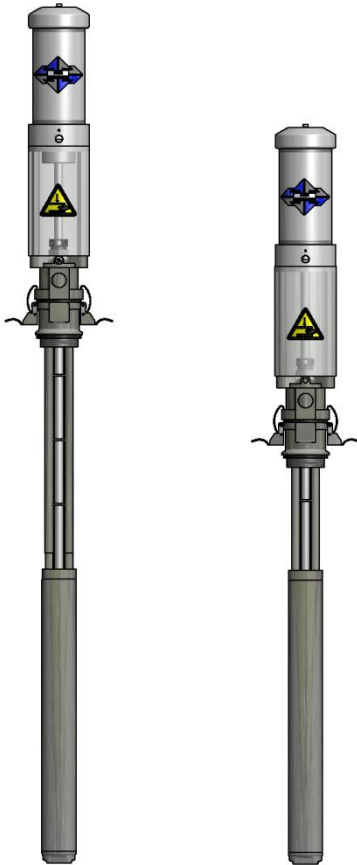

**POLYURETHANE
MACHINERY
CORPORATION**



High Output 2:1 Transfer Pump GHO

Service Manual

Ref. # MN-04010

Revision 5.2

November 15, 2016



Subscribe to our channel,
**Polyurethane Machinery
Corporation PMC**, for
video instructions.

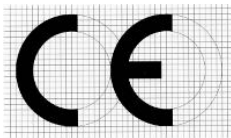

Polyurethane Machinery Corp.

Corporate: 1 Komo Drive, Lakewood, NJ 08701

Manufacturing: 2 Komo Drive, Lakewood, NJ 08701

Phone: 732-415-4400

Fax: 732-364-4025

URL: <http://www.polymac-usa.com>



Before installing the GHO Transfer Pump and start-up, carefully read all the technical and safety documentation included in this manual. Pay special attention to the information in order to know and understand the operation and the conditions of use of the GHO Transfer Pump. All of the information is aimed at improving user safety and avoiding possible breakdowns from the incorrect use of the GHO Transfer Pump.

Table of Contents

WARRANTY	2
SAFETY AND HANDLING	4
TECHNICAL SPECIFICATIONS	6
OPTIONAL EQUIPMENT	8
INITIAL MACHINE SET-UP	9
INSTALLATION	11
OPERATION	13
Daily Startup Procedures	13
Daily Shutdown Procedures	13
MAINTENANCE	14
Introduction.....	14
Disassembly	14
REPLACEMENT KITS	16
PART IDENTIFICATION	18
Transfer Pump Assembly.....	18
Air Motor Assembly.....	21
Air Motor and Plunger Top Assembly.....	22
Air Motor to Pump Coupling Assembly.....	23
Air Cylinder Cap Assembly	24
Foot Valve Assembly	25
Tool Kit	26
Transfer Pump Packages	27

WARRANTY

Polyurethane Machinery Corporation (hereinafter “PMC”) provides this **LIMITED WARRANTY** (hereinafter “Warranty”) to the original purchaser (hereinafter “Customer”) covering this equipment and the original PMC manufactured accessories delivered with the equipment (hereinafter “Product”) against defects in material or workmanship of the Product (hereinafter “Defect” or “Defective”) for a period of one (1) year from the date of first purchase as shown on the original PMC invoice (hereinafter “Warranty Period”).

If during the Warranty Period under normal use, the Product is suspected by Customer to be Defective in material or workmanship, it is Customer’s responsibility to contact PMC and return the Product to PMC as directed by PMC, freight prepaid. If PMC determines that the Product is Defective and that such Defect is covered by this Warranty, PMC will credit Customer for the reasonable freight charges incurred by Customer in returning the Defective Product to PMC, and PMC (or its authorized agent) will, at PMC’s option, repair or replace the Product, subject to the following:

Original Invoice: The original invoice must be kept as proof of the date of first sale and the Product serial number. The Warranty does not cover any Product if the Original Invoice appears to have been modified or altered, or when the serial number on the Product appears to have been altered or defaced.

Product Maintenance: It is the Customer’s responsibility to maintain the Product properly. See your maintenance schedule and owner’s manual for details. The Warranty does not cover an improperly maintained Product.

Non-PMC Components and Accessories: Non-PMC manufactured components and accessories that are used in the operation of the Product are not covered by this Warranty. Such components and accessories shall be subject to the warranty offered to the Customer, if any, by the original manufacturer of such component or accessory.

Other Warranty Exclusions: The Warranty does not cover any Product that PMC determines has been damaged or fails to operate properly due to misuse, negligence, abuse, carelessness, neglect, or accident. By way of example only, this includes:

- Normal wear and tear.
- Improper or unauthorized installation, repair, alteration, adjustment or modification of the Product.
- Use of heating devices, pumping equipment, dispensers, or other parts or accessories with the Product that have not been approved or manufactured by PMC.
- Failure to follow the operating instructions and recommendations provided by PMC may cause loss or damage to personnel, equipment, or work area.
- Fire, flood, “acts of God,” or other contingencies beyond the control of PMC.

THE WARRANTY DESCRIBED HEREIN IS THE EXCLUSIVE REMEDY FOR THE CUSTOMER AND IS IN LIEU OF ALL OTHER WARRANTIES, EXPRESS, IMPLIED, STATUTORY OR OTHERWISE, AND THE IMPLIED WARRANTIES OF MERCHANTABILITY AND FITNESS FOR A PARTICULAR PURPOSE AND ALL OTHER WARRANTIES ARE HEREBY DISCLAIMED. TO THE FULLEST EXTENT PERMITTED BY LAW, PMC SHALL NOT BE RESPONSIBLE, WHETHER BASED IN CONTRACT, TORT (INCLUDING, WITHOUT LIMITATION, NEGLIGENCE), WARRANTY OR ANY OTHER LEGAL OR EQUITABLE GROUNDS, FOR ANY CONSEQUENTIAL, INDIRECT, INCIDENTAL, LOST PROFITS, SPECIAL, PUNITIVE OR EXEMPLARY DAMAGES, WHETHER TO PERSON OR PROPERTY, ARISING FROM OR RELATING TO THE PRODUCT, EVEN IF PMC HAS BEEN ADVISED OF THE POSSIBILITY OF SUCH LOSSES OR DAMAGES.

Non-Warranty Service by PMC: If PMC determines that the suspected Defect of the Product is not covered by this Warranty, disposition of the Product will be made pursuant to the terms and conditions of PMC's written estimate on a time and materials basis.

Continuing Warranty for Products Repaired or Replaced under Warranty: Following the repair or replacement of a Product covered by this Warranty, such Product will continue to be subject to the original Warranty for the remainder of original Warranty Period or for three (3) months from the repair or replacement date, whichever is longer.

No Rights Implied: Nothing in the sale, lease or rental of any Product by PMC shall be construed to grant any right, interest or license in or under any patent, trademark, copyright, trade secret or other proprietary right or material owned by anyone; nor does PMC encourage the infringement of same.

Exclusive Warranty: This writing is the final, complete, and exclusive expression of the Warranty covering the Product. Any statements made by PMC, its employees or agents that differ from the terms of this Warranty shall have no effect. It is expressly understood that Customer's acceptance of this Warranty, by performance or otherwise, is upon and subject solely to the terms and conditions hereof, and any additional or different terms and conditions proposed or expressed by Customer or anyone, whether in writing or otherwise, are null and void unless specifically agreed to in writing by an Officer of PMC.

SAFETY AND HANDLING

This chapter contains important information on the safety, handling, and use of your GHO series high output transfer pump.



Before installing the GHO Transfer Pump and start-up, carefully read all the technical and safety documentation included in this manual. Pay special attention to the information in order to know and understand the operation and the conditions of use of the GHO Transfer Pump. All of the information is aimed at improving user safety and avoiding possible breakdowns from the incorrect use of the GHO Transfer Pump.

WARNING! Presents information to alert of a situation that might cause serious injuries if the instructions are not followed.

CAUTION! Presents information that indicates how to avoid damage to the equipment or how to avoid a situation that could cause injuries.

NOTE! Is relevant information of a procedure being carried out.

Careful study of this manual will enable the operator to know the characteristics of the pump and the operating procedures. By following the instructions and recommendations contained herein, you will reduce the potential risk of accidents in the installation, use, or maintenance of the GHO pump; you will provide a better opportunity for incident-free operation for a longer time, greater output, and the possibility of detecting and resolving problems quickly and simply.

Keep this Service Manual for future reference to useful information. If you lose this Manual, ask for a new copy from your PMC Service Center or go to the company website (www.polymac-usa.com).

The **GHO** 2:1 pump has been designed and built for the application of polyurea chemical systems, polyurethane foam chemical systems, and some two-component epoxy systems. Always use liquids and solvents that are compatible with the unit. In the event of doubt, consult your authorized PMC distributor.



To prevent possible injury caused by incorrect handling of the materials and solvents used in the process, carefully read the Material Safety Data Sheet (MSDS) provided by your supplier.



To avoid damage caused by the impact of pressurized fluids, do not open any connection or perform maintenance work on components subject to pressure until the pressure has been completely eliminated.



Use suitable protection when operating, maintaining or being present in the area where the equipment is functioning. This includes, but is not limited to, the use of protective goggles, gloves, shoes and safety clothing and breathing equipment.



To prevent serious injury through crushing or amputation, do not work with the equipment without the safety guards installed on the moving parts. Make sure that all the safety guards are completely reinstalled at the end of the repair or maintenance work of the equipment.



Deal with the waste caused according to current regulations.

TECHNICAL SPECIFICATIONS

Pressure Ratio: _____ 2.2:1
 Output (Cont. Duty): _____ 5.5 GPM (20.8 LPM)
 Output (Int. Duty): _____ 11 GPM (41.6 LPM)
 Cycles per Gallon: _____ 18.5
 Cycles per Liter: _____ 4.88
 Stroke Length: _____ 4 in (10.2 cm)
 Air Pressure: _____ 120 PSI (8.27 bar)
 Air Inlet: _____ 1/4 NPTF
 Fluid Outlet: _____ 3/4 NPTF
 Weight: _____ 25 lbs (11.4 kg)
 Air Consumption: _____ 2.0 CFM per gal @ 100 PSI (125 cc/s per liter @ 7 bar)

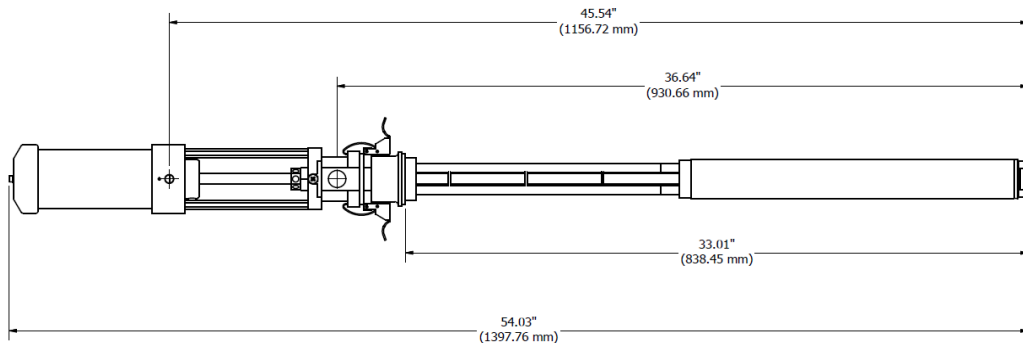

GHO Transfer Pump

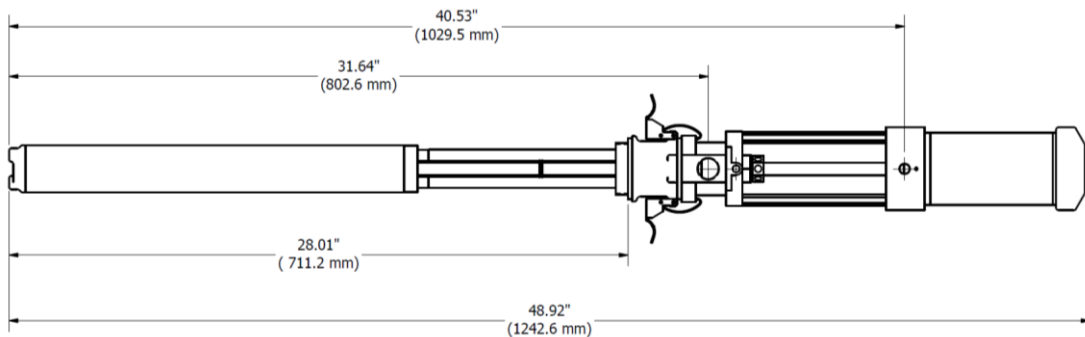

GHO-S Transfer Pump (Stubby)

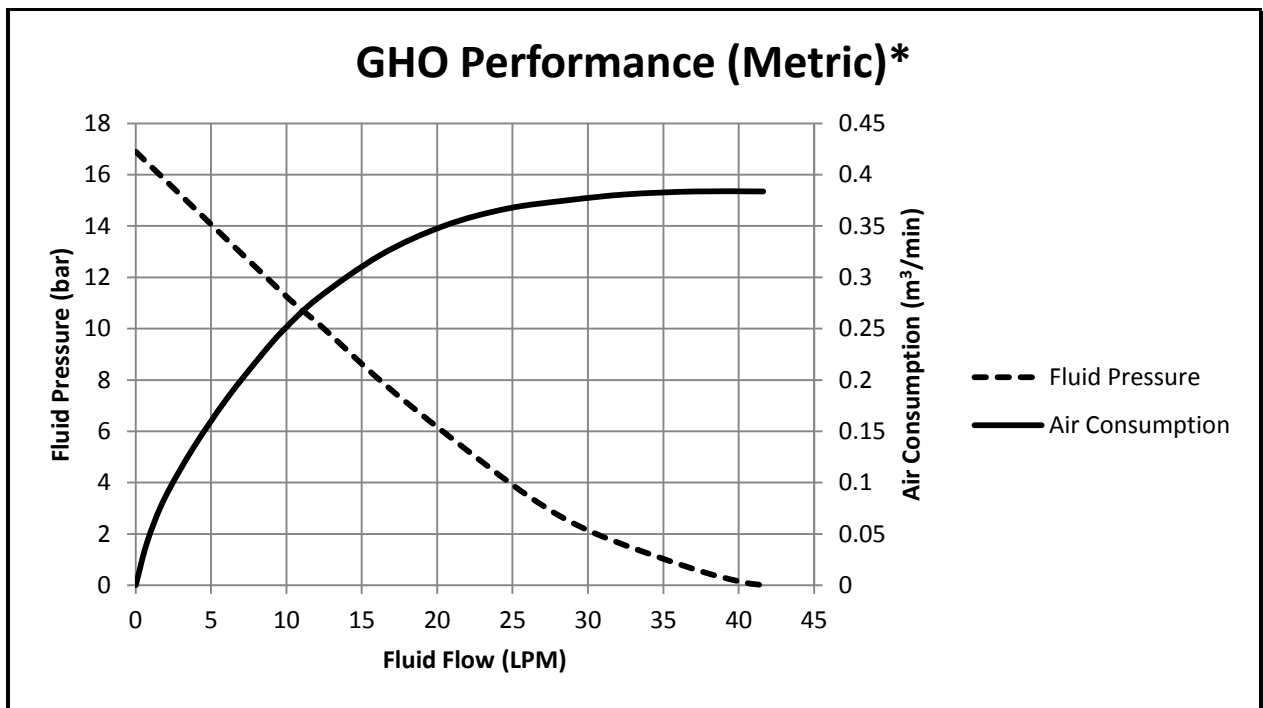
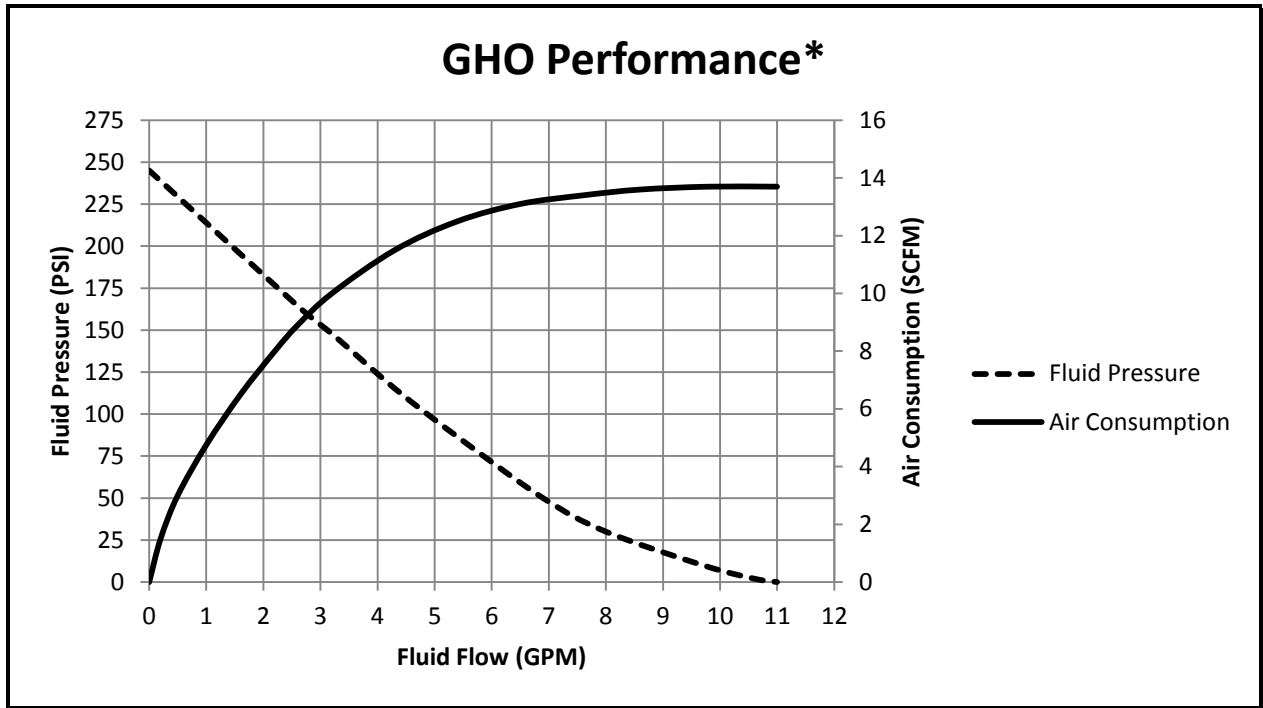

***Test Factors:**

¹Inlet Air Pressure: 110 PSI (7.6 bar)

²Test Fluid: Hydraulic Oil (Mobile DTE24)

OPTIONAL EQUIPMENT

Air Hose Assembly	
Part Number	Description
MA-00035A	Transfer Pump Air Harness; G-2
MA-00037A	Transfer Pump Air Harness; Air

Air Hose Assembly	
Part Number	Description
MA-00026	3/4x10' Poly Supply Hose
MA-00026-15	3/4x15' Poly Supply Hose
MA-00026-25	3/4x25' Poly Supply Hose
MA-00026-30	3/4x30' Poly Supply Hose
MA-00026-A	3/4x10' ISO Supply Hose
MA-00026-A-15	3/4x15' ISO Supply Hose
MA-00026-A-25	3/4x25' ISO Supply Hose
MA-00026-A-30	3/4x30' ISO Supply Hose

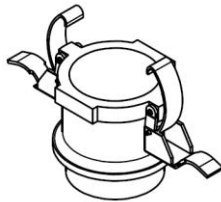
Bund Adapter	
	
Part Number	Description
PU-04000-33	Bund Adapter Assembly

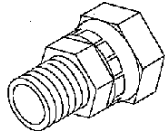
Swivel Unions	
	
Part Number	Description
PU-179-5	3/4 NPTM x 1/2 NPTF
PU-179-6	3/4 NPTM x 3/4 NPTF

INITIAL MACHINE SET-UP

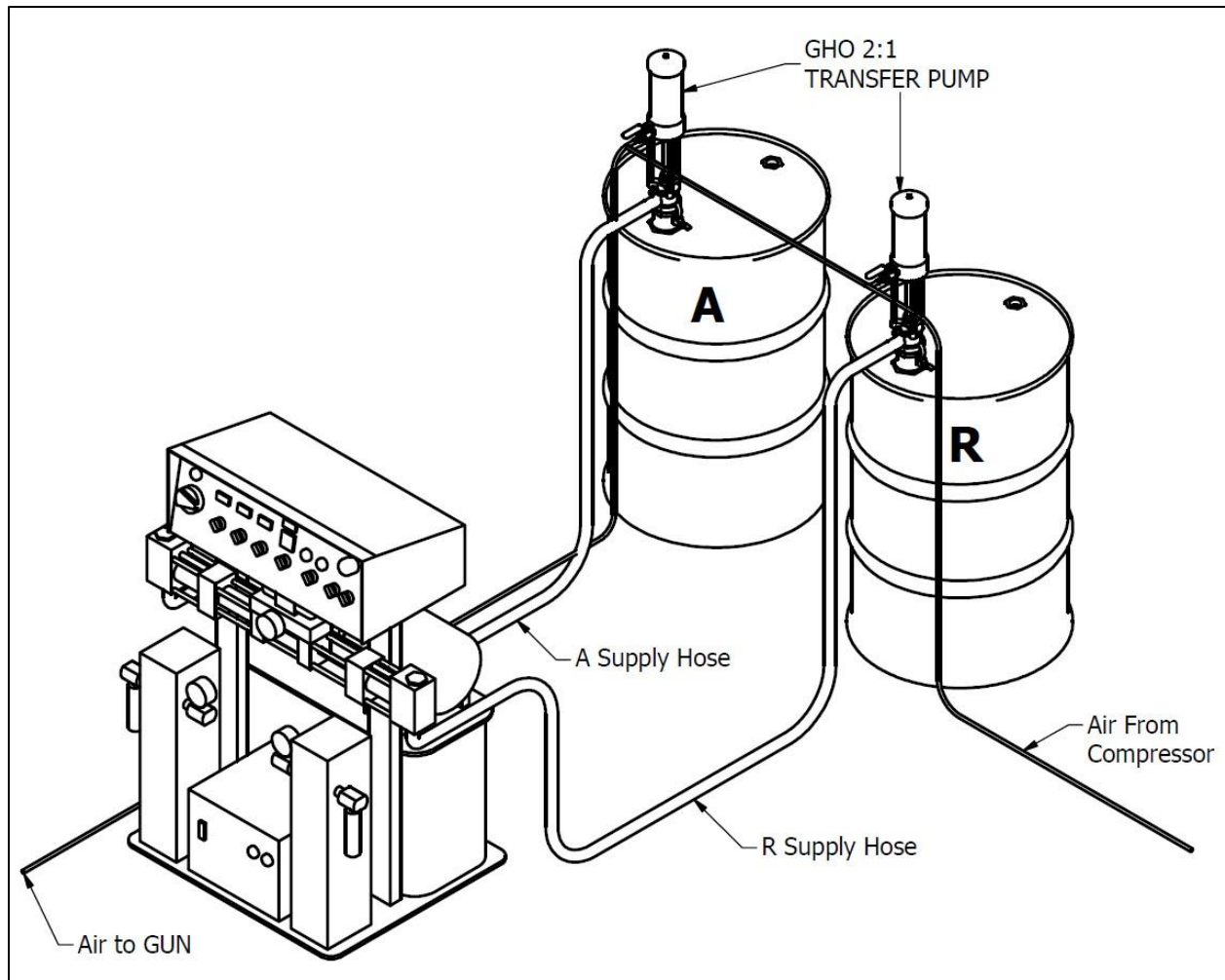

Typical Installation for Classic Hydraulic Proportioner

INSTALLATION

On custom installations, consult Technical Specifications (Pg. 6) for any dimensions required.

1. Make sure the Gasket (PU-04000-40) is in place on the threaded end of the Bung Adapter. Screw the Bung Adapter tightly into the bunghole of the drum. With the second gasket in place, insert the Transfer Pump through the Bung Adapter and lock it in place.

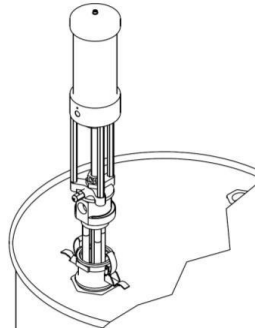

2. Use thread sealant on the male threads of the Air Valve and Quick Disconnect Plug

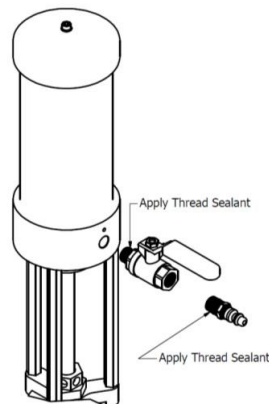

3. Use thread sealant on the male outlet fitting (not supplied as part of the pump assembly) and thread the fitting into the outlet port.

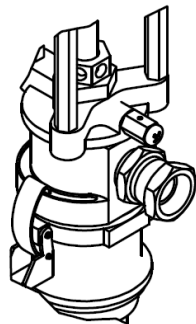

4. Install the air lines as required. PMC recommends using a 3/8" ID or larger air line to deliver air to the transfer pump

WARNING! Whenever you are using flammable materials, always connect a grounding wire to the air motor. Consult the National Electric Code, State, and Local Codes for additional information

5. Connect ground wire to the Grounding Lug in accordance with National, State, and Local Electrical Codes.
6. The transfer pump installation is complete.

CAUTION! The transfer pump incorporates a wet tube to prevent build-up of chemical and dirt on the pump shaft, which would damage the packings as the shaft moves through them.

NOTE! The wet tube must be full when storing a transfer pump outside the protected environment of a sealed drum without first thoroughly flushing and cleaning the pump. When installing a transfer pump into a partially filled drum where the liquid level is below the top of the wet tube, manually fill the tube with the proper chemical prior to inserting the transfer pump into the drum. If a drum with a transfer pump installed tips over, ensure that the wet tube is full after righting the drum.

CAUTION! The transfer pump pumps both resin and Isocyanate. To reduce the possibility of inadvertently using the transfer pump with the wrong chemical, PMC recommends color coding the transfer pumps red for Isocyanate and blue for resin.

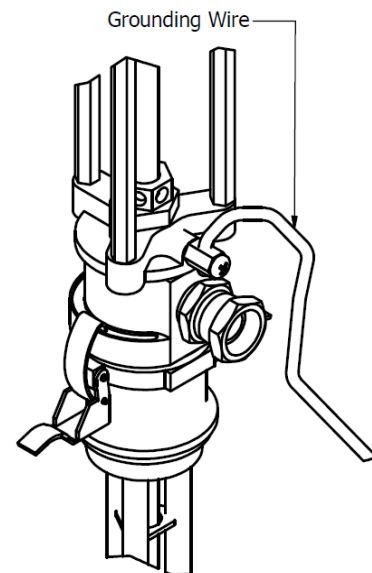
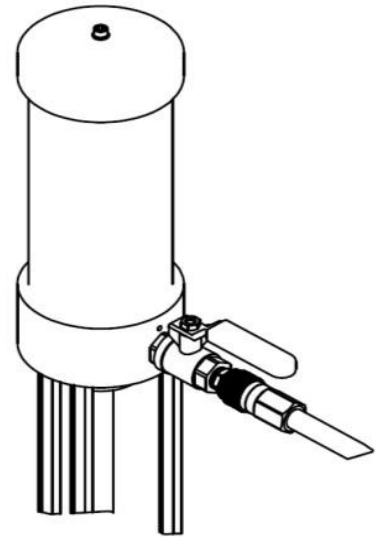

OPERATION

Daily Startup Procedures

1. Ensure main air supply is SHUT OFF before startup
2. Determine that the air valve is closed.
3. Connect the air line quick disconnect coupler to the transfer pump.
4. Turn on the main air supply.
5. Slowly open the air valve until the transfer pump runs slowing. Use the air valve to control the pump speed.



WARNING! Never allow the pump to run dry of pumping material. A dry pump will quickly accelerate to a high speed and possibly cause personal injury and/or damage to the pump. If the pump accelerates quickly or starts running too fast, stop it immediately and inspect. Do not attempt to operate the pump when it is not securely mounted in a drum. Keep hands clear of the area shown in Figure 12 at all times as personal injury may occur.

Daily Shutdown Procedures

1. Disconnect the air line coupler.
2. After the air pressure has bled off, close the air line valve.
3. For extended period shutdowns, flush, disassemble, and thoroughly clean the transfer pump before storing in a dry place.

MAINTENANCE

Introduction

WARNING! To avoid personal injury, always disconnect the air coupler and relieve all air and hydraulic pressures before servicing the pump.

NOTE! All threads are hand tight.

NOTE! When using a repair kit to service the pump, use all the parts provided in the kit regardless of the condition of the old ones. This will reduce the possibility of having to rebuild the pump sooner than normal.

Disassembly

1. Remove the Pinch Guard and place the transfer pump in a vice.

CAUTION! Do not clamp the transfer pump tightly.

NOTE! It might be necessary to place a strap wrench around the lower end of the suction tube when removing the foot valve.

2. Remove the foot valve housing using a 1-5/8" open-end wrench.

NOTE! Be sure to replace the bleed air plug when reassembling the cylinder. Failure to do so will prevent the transfer pump from operating.

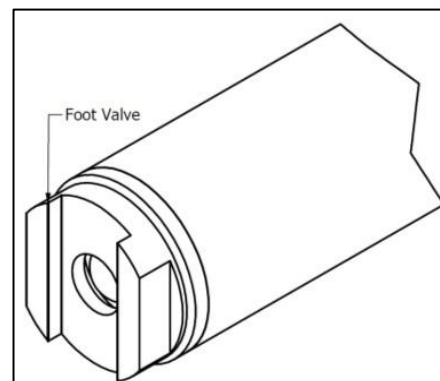
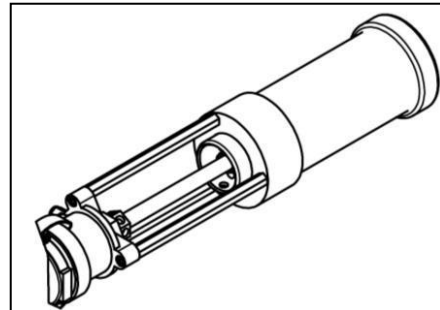

3. Remove the air bleed plug from the transfer pump air cap prior to disassembly of the air cylinder in order to bleed off any air pressure remaining in the cylinder.
 - a. Disconnect the air line to the transfer pump.
 - b. Open the air valve.

WARNING! *The air cylinder contains pressurized air, which must be completely exhausted prior to disassembly. Failure to do so may cause serious injury to personnel and/or property damage.*

4. Place a strap wrench around the lower end of the air cylinder and unthread.
5. Use a 5/16-inch diameter pin to keep the piston rod plunger from rotating. Unthread the piston.
6. Remove the dowel pin.
7. Push the piston out through the suction tube.

NOTE! *When replacing the packings, pay careful attention to the packing orientation.*

8. Inspect and replace the packings as required.
9. Lubricate, install, and assemble in reverse order.

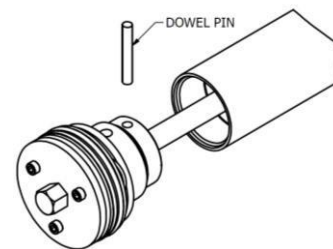
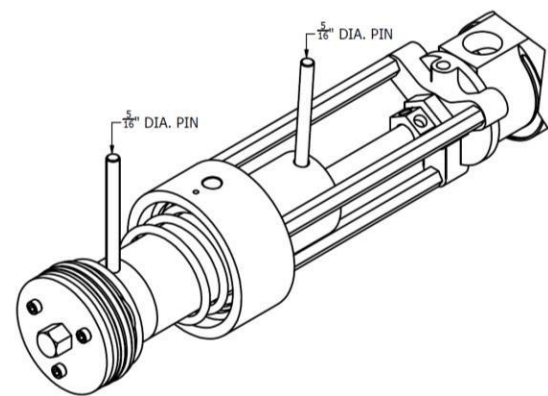
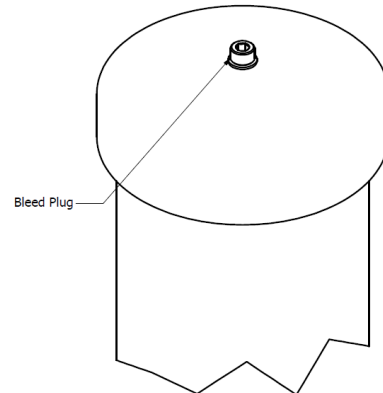

REPLACEMENT KITS

KT-GHO		
PART NUMBER	DESCRIPTION	QTY
PU-04000-88	O-RING	1
PU-04000-65	SEAL EXPANDER	1
PU-04000-42	O-RING	1
PU-04000-40	SQUARE O-RING	2
PU-04000-70	U-CUP	1
PU-04000-69	PISTON CUP PACKING	1
PU-04000-64	SEAL RETAINER	1
PU-04000-71	FE PACKING	2
PU-04000-68	GASKET	1
PU-04000-84	U-CUP	1
PU-04000-81	O-RING	2
PU-04000-46	ROLL PIN	1
PU-04000-67	WEAR RING	1
PU-04000-91	O-RING	2
PU-04000-47	ROLL PIN	1
PU-04000-72	COMPRESSION SPRING	1
PU-04000-85	WIPER	1
PU-04000-09	WEAR RING	1
PU-04000-10	U-CUP	1
PU-04000-80	O-RING	1
PU-04000-14	O-RING	1
PU-04000-15	GASKET TOP	1
PU-04000-92	SNAP RING	1
PU-04000-93	SNAP RING	1
GP-LOCTITE	LOCTITE	1
PU-04000-16	GASKET BOTTOM	3

KT-GHO-U		
PART NUMBER	DESCRIPTION	QTY
PU-04000-72	COMPRESSION SPRING	1
PU-04000-81	O-RING	2
PU-04000-84	U-CUP	1
PU-04000-15	GASKET TOP	1
PU-04000-09	WEAR RING	1
PU-04000-10	U-CUP	1
PU-04000-14	O-RING	1
PU-04000-80	O-RING	1
GP-LOCTITE	LOCTITE	1
PU-04000-16	GASKET BOTTOM	3

KT-GHO-L		
PART NUMBER	DESCRIPTION	QTY
PU-04000-68	GASKET	1
PU-04000-88	O-RING	1
PU-04000-69	PISTON CUP PACKING	1
PU-04000-70	U-CUP	1
PU-04000-67	WEAR RING	1
PU-04000-91	O-RING	2
PU-04000-92	SNAP RING	1
PU-04000-93	SNAP RING	1
PU-04000-40	SQUARE RING	2
PU-04000-64	SEAL RETAINER	1
PU-04000-71	FE PACKING	2
PU-04000-65	SEAL EXPANDER	1
PU-04000-85	WIPER	1
PU-04000-47	ROLL PIN	1
PU-04000-46	ROLL PIN	1
PU-04000-42	O-RING	1

PART IDENTIFICATION

Transfer Pump Assembly

(GHO)

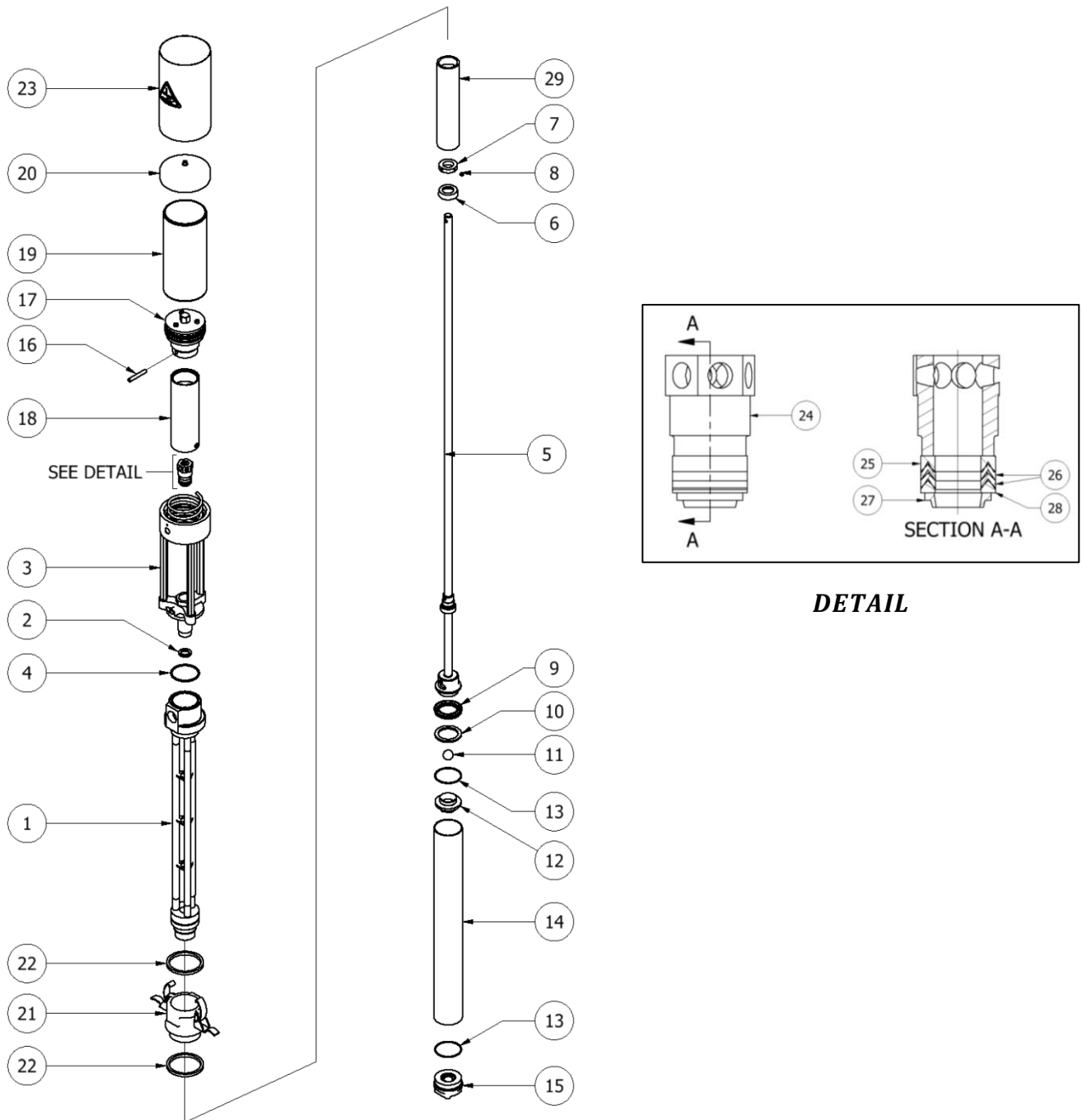

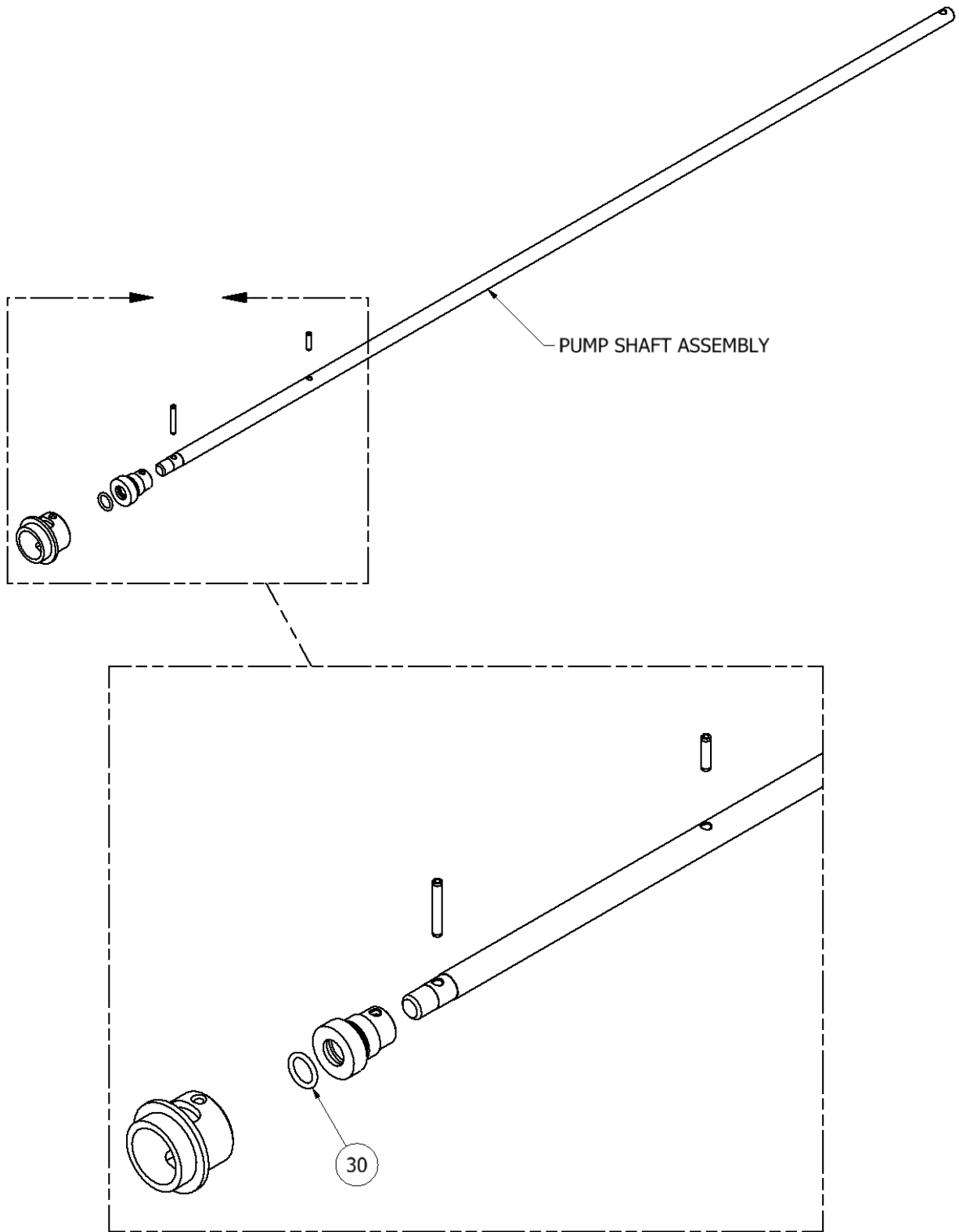

TRANSFER PUMP ASSEMBLY (GHO)			
ITEM	QTY	PART NUMBER	DESCRIPTION
1	1	PU-04000-24	PUMP BODY, GHO
	1	PU-04000-26-X	STUBBY PUMP BODY
2	1	PU-04000-68	PTFE GASKET
3	1	PU-04000-23	AIR MOTOR TO PUMP COUPLING ASSEMBLY
4	1	PU-04000-88	O-RING 2-137
5	1	PU-04000-41	PUMP SHAFT ASSEMBLY
6	1	PU-04000-69	PISTON CAP
7	1	PU-04000-59	U-CUP COLLAR
8	1	PU-04000-89	#8-32 SOFT TIP SET SCREW
9	1	PU-04000-70	U-CUP COLLAR
10	1	PU-04000-67	WEAR RING
11	1	PU-04000-90	3/4" SS BEARING BALL
12	1	PU-04000-53	PISTON HOUSING
13	2	PU-04000-91	O-RING 2-032
14	1	PU-04000-75	SUCTION TUBE
15	1	PU-04000-45	FOOT VALVE ASSEMBLY
16	1	PU-04000-79	DOWEL PIN
17	1	PU-04000-18	AIR MOTOR AND PLUNGER TOP ASSEMBLY
18	1	PU-04000-21	DISPLACEMENT PLUNGER
19	1	PU-04000-62	AIR CYLINDER
20	1	PU-04000-44	AIR CYLINDER CAP ASSEMBLY
21	1	PU-04000-33	BUNG ADAPTER ASSEMBLY
22	2	PU-04000-40	SQUARE GASKET
23	1	PU-04000-95	PINCH GUARD
24	1	PU-04000-61	PACKING NUT
25	1	PU-04000-64	SEAL RETAINER
26	2	PU-04000-71	FE PACKING
27	1	PU-04000-85	WIPER
28	1	PU-04000-65	SEAL EXPANDER
29	1	PU-04000-50	LOWER COMPRESSION TUBE
30	1	PU-04000-42	ORING #113 VITON

Air Motor Assembly

(PU-04000-01)

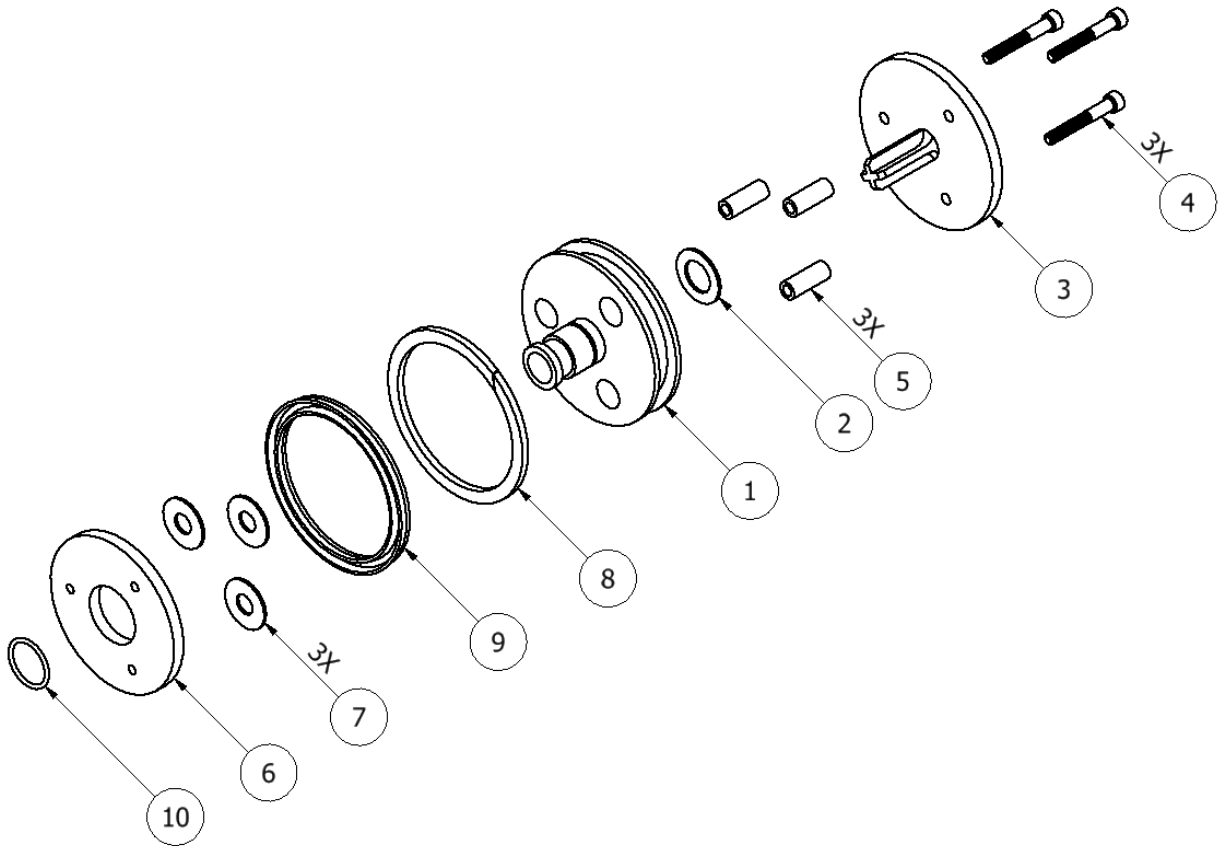

AIR MOTOR ASSEMBLY (PU-04000-01)			
ITEM	QTY	PART NUMBER	DESCRIPTION
1	1	PU-04000-11	AIR PISTON
2	1	PU-04000-15	GASKET TOP
3	1	PU-04000-03	UPPER AIR VALVE ASSEMBLY
4	3	PU-04000-02	#10-32 X 1-5/16 SHCS
5	3	PU-04000-08	SPACER 28/32
6	1	PU-04000-13	WEAWR RING
7	3	PU-04000-16	GASKET BOTTOM
8	1	PU-04000-09	WEAR RING
9	1	PU-04000-10	U-CUP
10	1	PU-04000-14	O-RING 2-018

Air Motor and Plunger Top Assembly

(PU-04000-18)

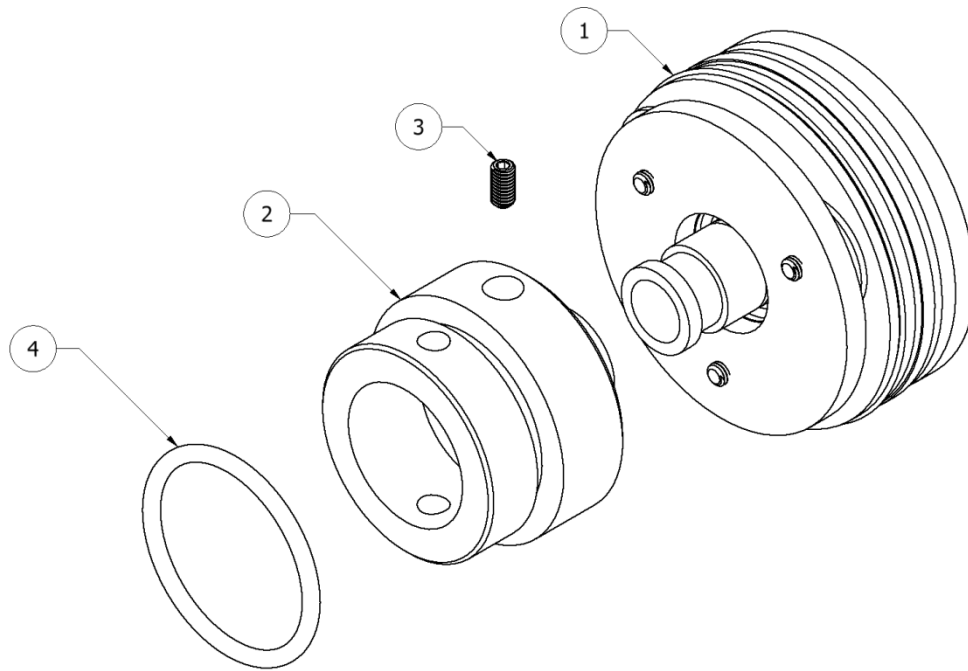

AIR MOTOR AND PLUNGER TOP ASSEMBLY (PU-04000-18)			
ITEM	QTY	PART NUMBER	DESCRIPTION
1	1	PU-04000-01	AIR MOTOR ASSEMBLY (PAGE 21)
2	1	PU-04000-60	PLUNGER TOP
3	1	PU-04000-78	#10-32 X 3/8 SET SCREW
4	1	PU-04000-80	O-RING 2-223

Air Motor to Pump Coupling Assembly

(PU-04000-23)

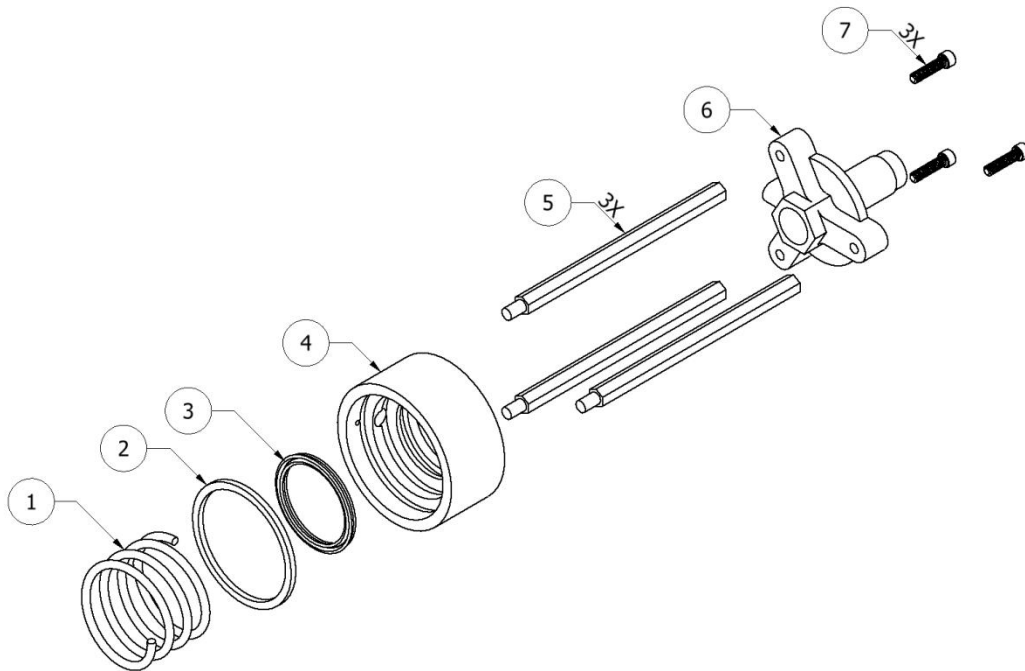

AIR MOTOR TO PUMP COUPLING ASSEMBLY (PU-04000-23)			
ITEM	QTY	PART NUMBER	DESCRIPTION
1	1	PU-04000-73	SPRING
2	1	PU-04000-81	SQUARE O-RING
3	1	PU-04000-84	U-CUP
4	1	PU-04000-49	AIR CYLINDER BASE
5	3	PU-04000-63	THREADED STANDOFF
6	1	PU-04000-51	AIR CYLINDER MOUNTING FLANGE
7	3	PU-04000-87	1/4-20 X 1 SHCS

Air Cylinder Cap Assembly

(PU-04000-44)

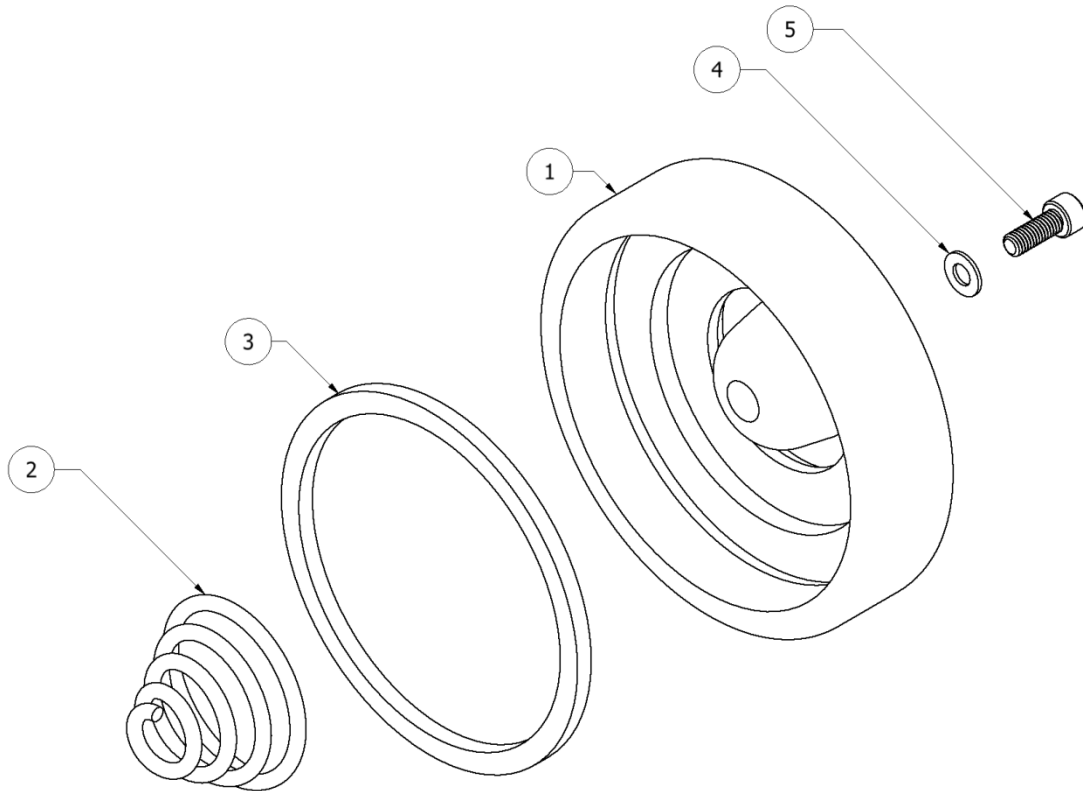

AIR CYLINDER CAP ASSEMBLY (PU-04000-44)			
ITEM	QTY	PART NUMBER	DESCRIPTION
1	1	PU-04000-43	CAP AND BUMPER ASSEMBLY
	1	PU-04000-17	AIR CYLINDER CAP
	1	PU-04000-20	BUMPER
2	1	PU-04000-72	SPRING
3	1	PU-04000-81	SQUARE O-RING
4	1	PU-04000-77	FIBER WASHER
5	1	PU-04000-57	#10-32 X 1/2 PRESSURE RELIEF SCREW

Foot Valve Assembly

(PU-04000-45)

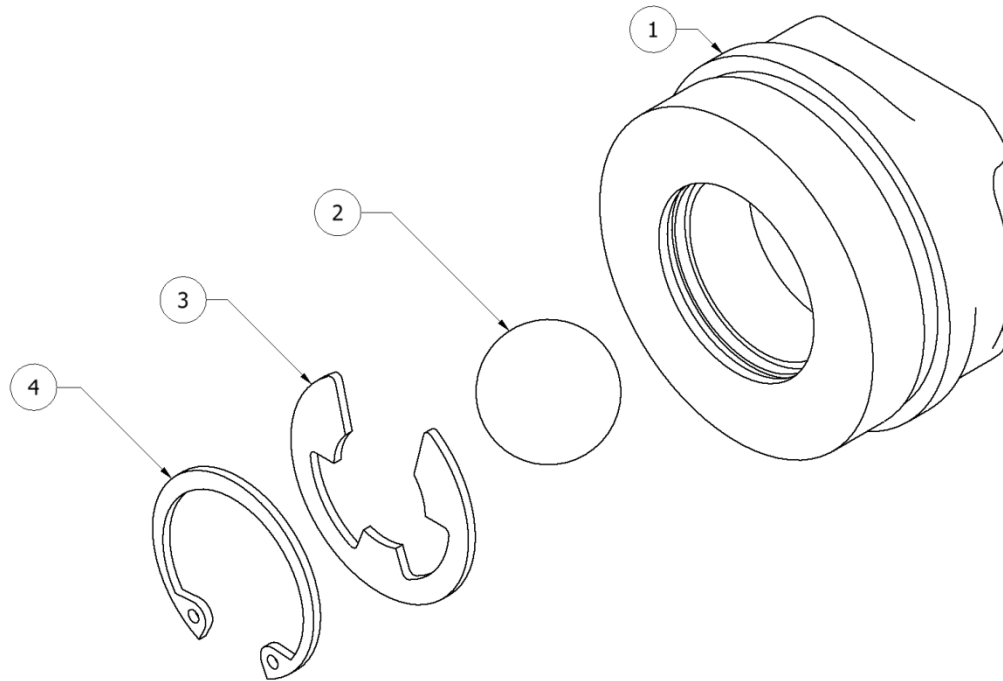

FOOT VALVE ASSEMBLY (PU-04000-45)			
ITEM	QTY	PART NUMBER	DESCRIPTION
1	1	PU-04000-55	FOOT VALVE HOUSING
2	1	PU-04000-90	3/4" SS BEARING BALL
3	1	PU-04000-93	E-RING 5133-75
4	1	PU-04000-92	SNAP RING N5000-106

Tool Kit

(PU-04000-94)

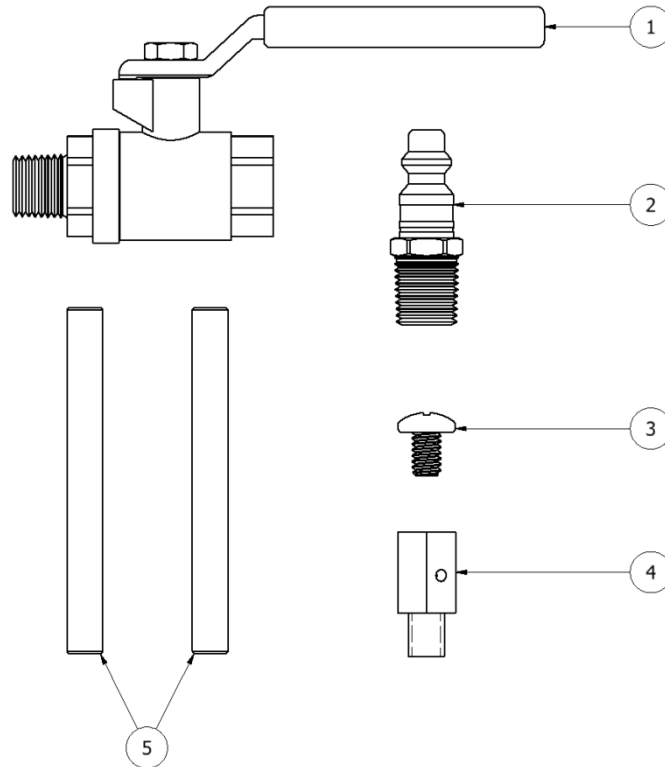

TOOL KIT (PU-04000-94)			
ITEM	QTY	PART NUMBER	DESCRIPTION
1	1	PU-04000-82	BALL VALVE
2	1	PU-04000-83	AIR FITTING
3	1	PU-04000-86	1/4-20 X 1/2 MACHINE SCREW
4	1	PU-04000-66	GROUNDING LUG
5	2	PU-04000-106	SPANNER PIN

Transfer Pump Packages

TRANSFER PUMP PACKAGE, AIR MACHINE GHO-A-PKG			
ITEM	QTY	PART NUMBER	DESCRIPTION
1	2	GHO	TRANSFER PUMP 2:1
2	1	MA-00026	3/4X10' POLY SUPPLY HOSE
3	1	MA-00026-A	3/4X10' ISO SUPPLY HOSE
4	1	MA-00037A	TRANSFER PUMP AIR HARNESS, AIR
5	1	PU-179-5	3/4 NPT X 1/2 NPT (F)
6	1	PU-179-6	3/4 NPT X 3/4 NPT (F)

TRANSFER PUMP PACKAGE, HYDRAULIC MACHINE GHO-H-PKG			
ITEM	QTY	PART NUMBER	DESCRIPTION
1	2	GHO	TRANSFER PUMP 2:1
2	1	MA-00026	3/4X10' POLY SUPPLY HOSE
3	1	MA-00026-A	3/4X10' ISO SUPPLY HOSE
4	1	MA-00035A	TRANSFER PUMP AIR HARNESS: G2
5	1	PU-179-5	3/4 NPT X 1/2 NPT (F)
6	1	PU-179-6	3/4 NPT X 3/4 NPT (F)