



**POLYURETHANE
MACHINERY
CORPORATION**



Mechanical Purge Spray & Pour Gun PX-7

**For use with non-flammable Foam and
Polyurea**

For professional use only

Not for use in explosive atmospheres

Service Manual

Ref. # MN-04028

Revision 2.3

March 2, 2021



Subscribe to our YouTube channel, "Polyurethane Machinery Corporation PMC", for video instructions.



Polyurethane Machinery Corp.

Corporate: 1 Komo Drive, Lakewood, NJ 08701

Manufacturing: 2 Komo Drive, Lakewood, NJ 08701

Phone: 732-415-4400

Fax: 732-364-4025

URL: <http://www.polymacusa.com>



Before installing the PX-7 Gun and start-up, carefully read all the technical and safety documentation included in this manual. Pay special attention to the information in order to know and understand the operation and the conditions of use of the PX-7 Gun. All of the information is aimed at improving user safety and avoiding possible breakdowns from the incorrect use of the PX-7 Gun.

Table of Contents

WARRANTY	1
SAFETY AND HANDLING	3
TECHNICAL SPECIFICATIONS	5
GENERAL DESCRIPTION	6
OPERATION	7
Mixing Module and PCD Installation.....	10
Valving Rod Adjustment.....	12
Rear Packing Nut Adjustment	13
Air Cap Valve Adjustment	14
Shutdown Procedure.....	14
MAINTENANCE	15
Daily Cleaning Procedure.....	16
TROUBLE SHOOTING GUIDE	18
REFERENCE GUIDE	19
Spray Module Kits.....	19
Pour Module Kits.....	19
Module Drills	19
PCD Sizes	19
Torque Specifications.....	20
Flush Tanks	20
PARTS IDENTIFICATION	21
Gun Assembly.....	21
Gun Block Assembly	22
Air Cylinder Assembly	23
Handle Assembly	25
Coupling Block Assembly	26
Manual Valve Assembly	27
Spray Module Components.....	28
Pour Module Components.....	29
SPARE PARTS & REBUILD KITS	30
PX-7 Tool Kit.....	30
Cylinder/Piston Rebuild Kit.....	32
Trigger Rebuild Kit	32
Gun Block Rebuild Kit, PX-7	32
Screen Screw Kit, A-Side, PX-7	33
Screen Screw Kit, R-Side, PX-7	33

1/4" Unheated Stainless Steel Hose Assy	33
PX-7 Spare Parts Kits	34
Kit List	35
SLAB JACKING & CONCRETE POURING COMPONENTS	36
PX-7 Slab Jack Starter Kit.....	36
Plastic Packer w/ Sleeve – 6 Pack	36
Starter Pack, 3/8 Bang-In Pack	37

Table of Figures

Figure 1: PX-7 Dimensions	5
Figure 2: PX-7 Overview	6
Figure 3: PX-7 Side View	6
Figure 4: Safety Stop	7
Figure 5: Closing Manual Valves.....	7
Figure 6: Coupling Block Hose Installation	8
Figure 7: Coupling Block Gaskets	8
Figure 8: Air Inlet Configuration Options.....	9
Figure 9: Turn Forward Stop Clockwise	10
Figure 10: Spray Configuration	11
Figure 11: Pour Configuration	11
Figure 12: Valving Rod Adjustment	12
Figure 13: Rear Packing Nut	13
Figure 14: Air Cap Valve Adjustment	14
Figure 15: Flush Block Installation.....	16
Figure 16: Clean Parts	17
Figure 17: 2.5 Gallon Flush Tank (200426)	20
Figure 18: 1 QT Mini Flush Tank (200216).....	20
Figure 19: Kit MA-41 Shown on PX-7.....	33

WARRANTY

Polyurethane Machinery Corporation (hereinafter “PMC”) provides this **LIMITED WARRANTY** (hereinafter “Warranty”) to the original purchaser (hereinafter “Customer”) covering this equipment and the original PMC manufactured accessories delivered with the equipment (hereinafter “Product”) against defects in material or workmanship of the Product (hereinafter “Defect” or “Defective”) for a period of one (1) year from the date of first purchase as shown on the original PMC invoice (hereinafter “Warranty Period”).

If during the Warranty Period under normal use, the Product is suspected by Customer to be Defective in material or workmanship, it is Customer’s responsibility to contact PMC and return the Product to PMC as directed by PMC, freight prepaid. If PMC determines that the Product is Defective and that such Defect is covered by this Warranty, PMC will credit Customer for the reasonable freight charges incurred by Customer in returning the Defective Product to PMC, and PMC (or its authorized agent) will, at PMC’s option, repair or replace the Product, subject to the following:

Original Invoice: The original invoice must be kept as proof of the date of first sale and the Product serial number. The Warranty does not cover any Product if the Original Invoice appears to have been modified or altered, or when the serial number on the Product appears to have been altered or defaced.

Product Maintenance: It is the Customer’s responsibility to maintain the Product properly. See your maintenance schedule and owner’s manual for details. The Warranty does not cover an improperly maintained Product.

Non-PMC Components and Accessories: Non-PMC manufactured components and accessories that are used in the operation of the Product are not covered by this Warranty. Such components and accessories shall be subject to the warranty offered to the Customer, if any, by the original manufacturer of such component or accessory.

Other Warranty Exclusions: The Warranty does not cover any Product that PMC determines has been damaged or fails to operate properly due to misuse, negligence, abuse, carelessness, neglect, or accident. By way of example only, this includes:

- Normal wear and tear.
- Improper or unauthorized installation, repair, alteration, adjustment or modification of the Product.
- Use of heating devices, pumping equipment, dispensers, or other parts or accessories with the Product that have not been approved or manufactured by PMC.
- Use of air tool oil for lubricating the product
- Failure to follow the operating instructions and recommendations provided by PMC may cause loss or damage to personnel, equipment, or work area.
- Fire, flood, “acts of God,” or other contingencies beyond the control of PMC.

THE WARRANTY DESCRIBED HEREIN IS THE EXCLUSIVE REMEDY FOR THE CUSTOMER AND IS IN LIEU OF ALL OTHER WARRANTIES, EXPRESS, IMPLIED, STATUTORY OR OTHERWISE, AND THE IMPLIED WARRANTIES OF MERCHANTABILITY AND FITNESS FOR A PARTICULAR PURPOSE AND ALL OTHER WARRANTIES ARE HEREBY DISCLAIMED. TO THE FULLEST EXTENT PERMITTED BY LAW, PMC SHALL NOT BE RESPONSIBLE, WHETHER BASED IN CONTRACT, TORT (INCLUDING, WITHOUT LIMITATION, NEGLIGENCE), WARRANTY OR ANY OTHER LEGAL OR EQUITABLE GROUNDS, FOR ANY CONSEQUENTIAL, INDIRECT, INCIDENTAL, LOST PROFITS, SPECIAL, PUNITIVE OR EXEMPLARY DAMAGES, WHETHER TO PERSON OR PROPERTY, ARISING FROM OR RELATING TO THE PRODUCT, EVEN IF PMC HAS BEEN ADVISED OF THE POSSIBILITY OF SUCH LOSSES OR DAMAGES.

Non-Warranty Service by PMC: If PMC determines that the suspected Defect of the Product is not covered by this Warranty, disposition of the Product will be made pursuant to the terms and conditions of PMC's written estimate on a time and materials basis.

Continuing Warranty for Products Repaired or Replaced under Warranty: Following the repair or replacement of a Product covered by this Warranty, such Product will continue to be subject to the original Warranty for the remainder of original Warranty Period or for three (3) months from the repair or replacement date, whichever is longer.

No Rights Implied: Nothing in the sale, lease or rental of any Product by PMC shall be construed to grant any right, interest or license in or under any patent, trademark, copyright, trade secret or other proprietary right or material owned by anyone; nor does PMC encourage the infringement of same.

Exclusive Warranty: This writing is the final, complete, and exclusive expression of the Warranty covering the Product. Any statements made by PMC, its employees or agents that differ from the terms of this Warranty shall have no effect. It is expressly understood that Customer's acceptance of this Warranty, by performance or otherwise, is upon and subject solely to the terms and conditions hereof, and any additional or different terms and conditions proposed or expressed by Customer or anyone, whether in writing or otherwise, are null and void unless specifically agreed to in writing by an Officer of PMC.

SAFETY AND HANDLING

This chapter contains important information on the safety, handling and use of your PX-7 Gun.



Before installing the PX-7 Gun and start-up, carefully read all the technical and safety documentation included in this manual. Pay special attention to the information in order to know and understand the operation and the conditions of use of the PX-7 Gun. All of the information is aimed at improving user safety and avoiding possible breakdowns from the incorrect use of the PX-7 Gun.

WARNING! Presents information to alert of a situation that might cause serious injuries if the instructions are not followed.

CAUTION! Presents information that indicates how to avoid damage to the equipment or how to avoid a situation that could cause injuries.

NOTE! Is relevant information of a procedure being carried out.

Careful study of this Manual will enable the operator to know the characteristics of the Gun and the operating procedures. By following the instructions and recommendations contained, you will reduce the potential risk of accidents in the installation, use or maintenance of the PX-7 Gun; you will provide a better opportunity for incident-free operation for a longer time, greater productivity and the possibility of detecting and resolving problems fast and simply.

Keep this Service Manual for future reference to useful information. If you lose this Manual, ask for a new copy from your PMC Service Center or go to the company website (www.polymacusa.com).

The PX-7 Gun has been designed and built for the application of polyurea chemical systems, polyurethane foam chemical systems and some two-component epoxy systems.

WARNING! The design and configuration of the PX-7 Gun does not allow its use in potentially explosive atmospheres or exceeding the pressure and temperature limits described in the Technical Specifications of this Manual to be exceeded.

Always use liquids and solvents that are compatible with the PX-7 Gun. If in doubt, consult PMC Technical Service.

When working with the PX-7 Gun, it is recommended that the operator wear suitable clothing and elements of personal protection, including, without limitation, gloves, protective goggles, safety footwear and face masks. Use breathing equipment when working with the Gun in enclosed spaces or in areas with insufficient ventilation. The introduction and follow-up of safety measures must not be limited to those described in this Manual. Before beginning to work with the Gun, a comprehensive analysis must be made of the risks derived from the products to be dispensed, the type of application and the working environment.



To prevent possible injury caused by incorrect handling of the materials and solvents used in the process, carefully read the Safety Data Sheet (SDS) provided by your supplier.



To avoid damage caused by the impact of pressurized fluids, do not open any connection or perform maintenance work on components subject to pressure until the pressure has been completely eliminated.



Use suitable protection when operating, maintaining or being present in the area where the equipment is functioning. This includes, but is not limited to, the use of protective goggles, gloves, shoes and safety clothing and breathing equipment.



The equipment includes components that reach high temperatures and can cause burns. Hot parts of the equipment must not be handled or touched until they have cooled completely.



The equipment sprays high pressure fluids that can lead to fluid being injected under the skin or eyes. Severe injury could be incurred. Proper personal protective equipment should be used in conjunction with training and situational awareness of all personnel on the job.

TECHNICAL SPECIFICATIONS

Maximum Working Pressure:.....3,500 psi (245 Bar)
 Required Incoming Air Pressure: 90-125 psi (6.2-8.6 Bar)
 Weight (Not including Coupling Block): 4.3 lbs (2.0 kg)
 Weight (Including Coupling Block):..... 5.0 lbs (2.3 kg)

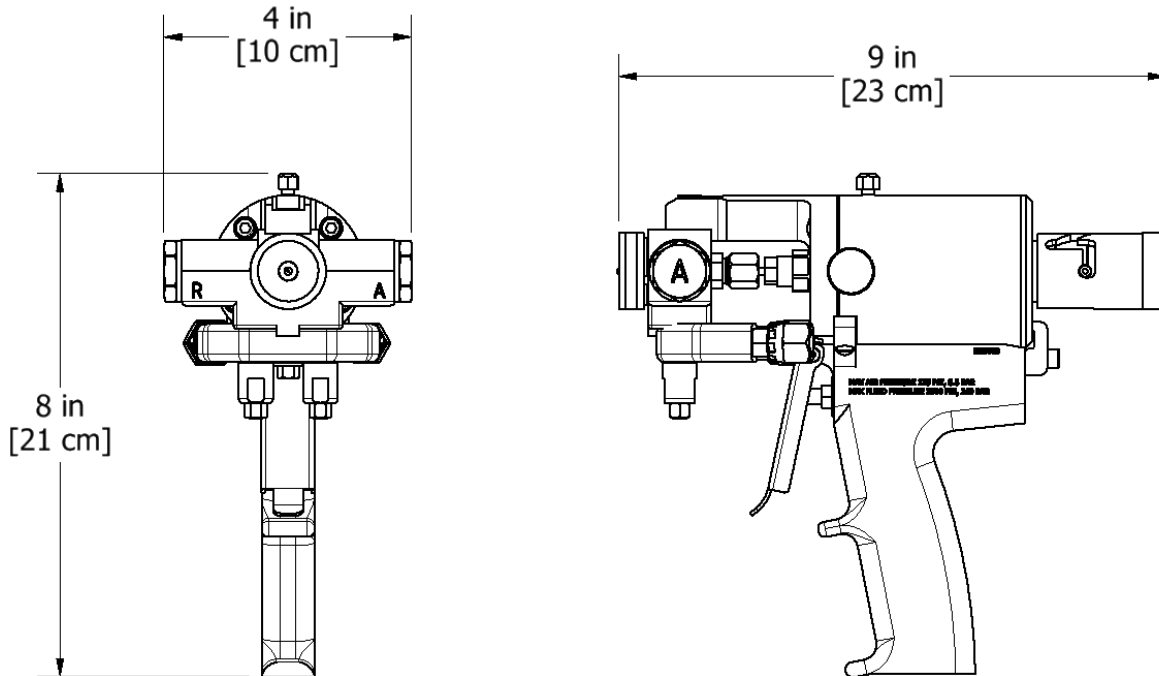

Figure 1: PX-7 Dimensions

Flow Rates of Spray Modules				
MODULE #	MODULE KIT PART #	PRESSURE (PSI)	OUTPUT (LB/MIN)	PATTERN DIA. (IN)
#1 Round	200547	1000	22	22
#3 Round	200549	1000	12	12
#5 Round	200551	1600	16	14

GENERAL DESCRIPTION

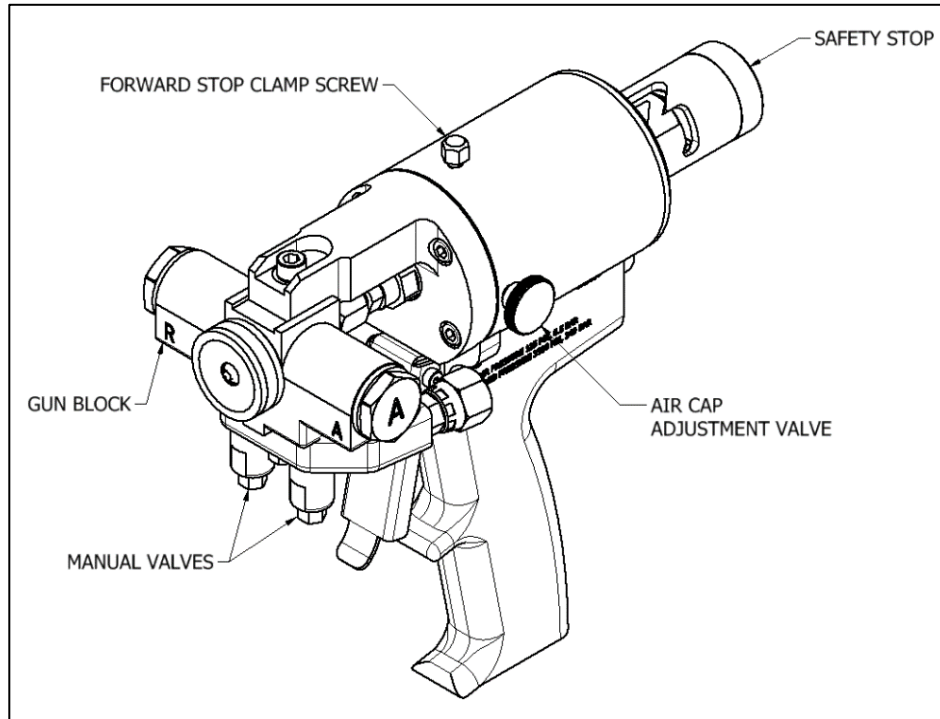

Figure 2: PX-7 Overview

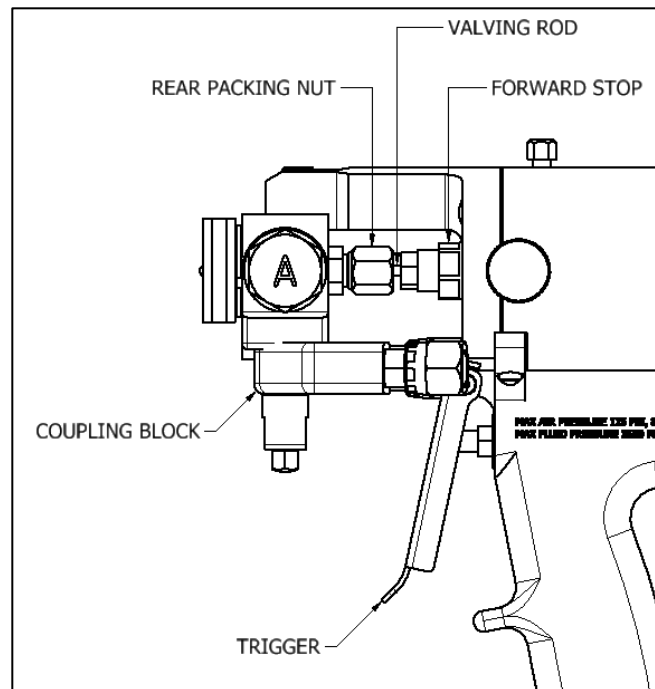

Figure 3: PX-7 Side View

OPERATION

CAUTION! When working with the PX-7 Gun or performing maintenance work, wear suitable safety protection in accordance with the recommendations and specifications provided by the product suppliers.

1. Set the **Safety Stop** to the **LOCKED** position (see Figure 4).

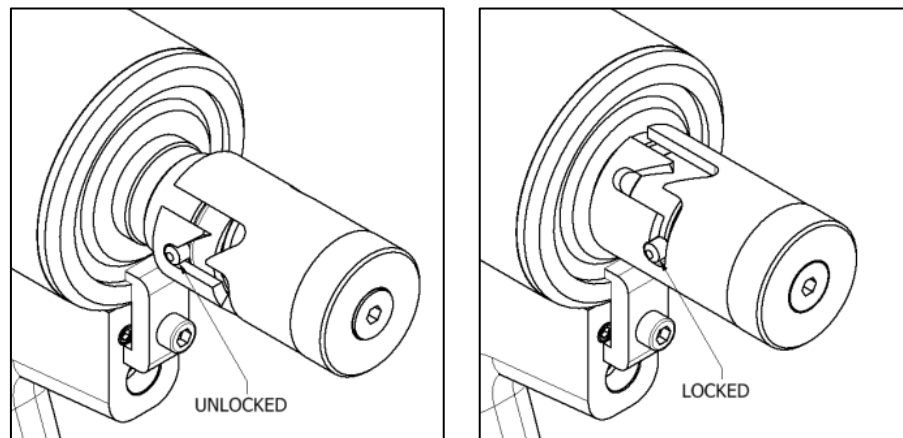

Figure 4: Safety Stop

2. Ensure the **Manual Valves** are **CLOSED** by turning them to the full clockwise position using supplied 5/16" nut driver. (See Figure 5).

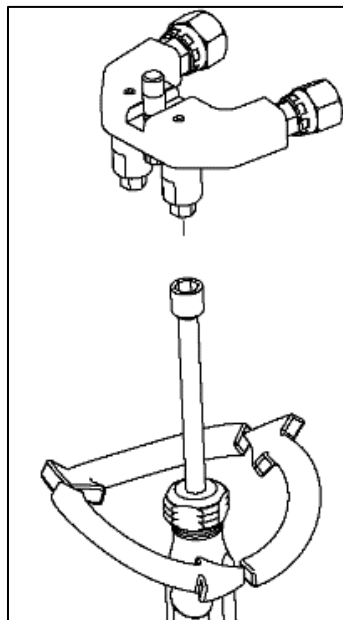

Figure 5: Closing Manual Valves

3. Install hose to the **Coupling Block** (see Figure 6).

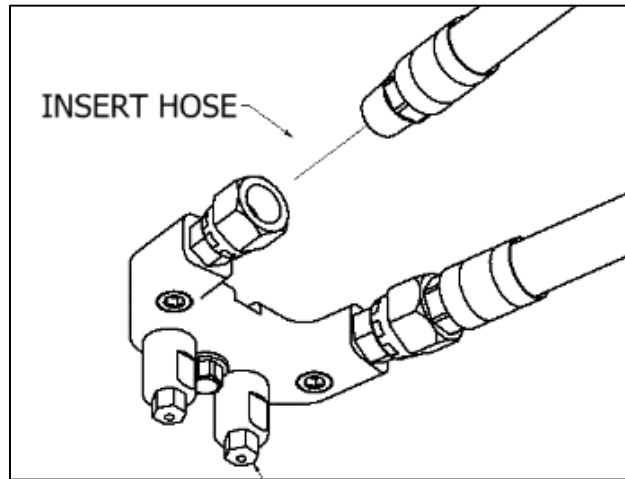

Figure 6: Coupling Block Hose Installation

NOTE! The material delivery hoses are color coded Red and Blue. The Red corresponds to the Isocyanate (A) and the Blue to the Polyol (R). To avoid connection errors, the (A) and (B) hoses have connections with different sizes to avoid incorrect connections.

CAUTION! Excessive force closing or opening the Manual Valves may result in damage to the Manual Valves and/or Coupling Block. Never use a socket wrench to close the manual valves.

4. Ensure the **Coupling Block Gaskets** are installed in the **Gun Block**. Replace if necessary (see Figure 7).

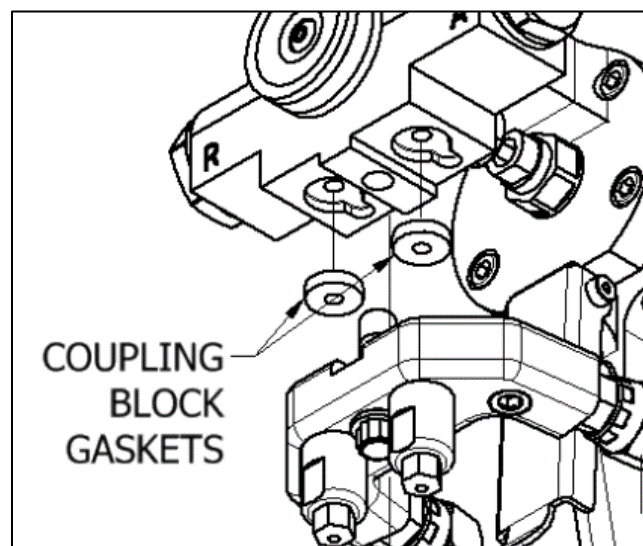

Figure 7: Coupling Block Gaskets

5. Connect the **Coupling Block** to the **Gun Block** using the **Nut Driver** provided. Tighten the **Coupling Block** until there is a hand tight seal.
6. Connect the **Air Hose** to the **Air Inlet** at the back of the **Gun**, and then connect the **Air Hose** to the **Supply Air Hose**.

Alternatively, remove the **Pipe Plug** from inside the **Gun Handle** and replace with the supplied **Pipe Extension**. Connect the **Air Hose** and **Adapter** to the **Pipe Extension**, and then connect the **Air Hose** to the **Supply Air Hose** (see Figure 8).

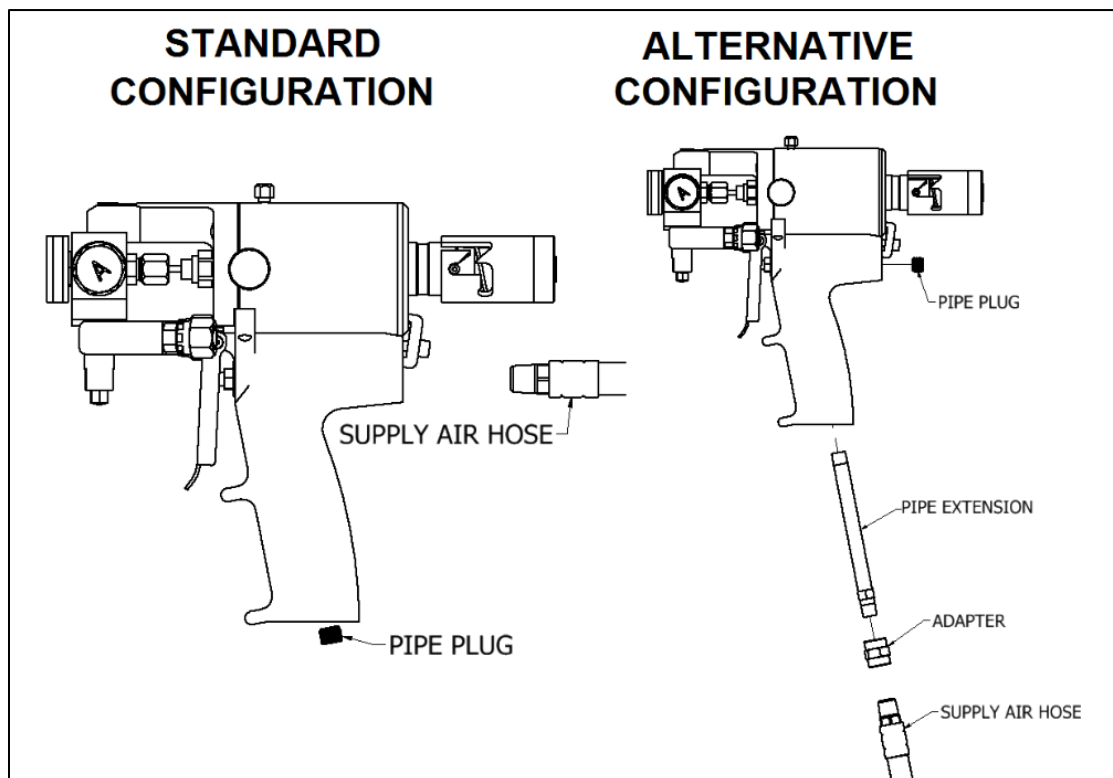

Figure 8: Air Inlet Configuration Options

7. Pull the **Trigger** several times to check for correct movement of the **Valving Rod**.
8. Ensure the Proportioner and supply system are in the ready position and all processing parameters are satisfied per the chemical manufacturer's specifications.
9. **OPEN** each **Manual Valve** by turning three (3) full turns counter clockwise.
10. Set the **Safety Stop** to the **OPEN** position.
11. Perform a test spray.

Mixing Module and PCD Installation

1. Remove the **Coupling Block** from the **Gun**.
2. Flush the **Gun Block** per the Daily Cleaning Procedure on page 16
3. Remove the **Air Cap**, **PCD Retainer**, **PCD**, **Front Packing Retainer** with the **Front Packing**, and the **Mixing Module** as applicable
4. Ensure the **Air Hose** is connected to the **Supply Air Hose**, and the gun is in the **Unlocked** position
5. Push **Mixing Module** into **Gun Block** onto **Valving Rod** (See Figure 10 and Figure 11).
6. Pull and hold the **Trigger** until after step 8
7. Screw the **Front Packing Retainer** (with **Front Packing** for spray applications) onto the **Gun Block** until it is hand tight
8. Tighten the **Front Packing Retainer** with a 5/8" Wrench and release the **Trigger**
9. If **Module** has been used previously, skip to step 12, for initial **Module** install, remove **Front Packing Retainer** (with **Front Packing** if applicable) and **Module** (pull **Trigger** to release **Module**)
10. Clean out orifices in **Module** using supplied **Drills**
11. Reinstall **Module** and **Front Packing Retainer** (with **Front Packing** if applicable)
12. Turn the **Forward Stop** clockwise (as viewed from the front of the gun) approximately 1-2 turns (see Figure 9).

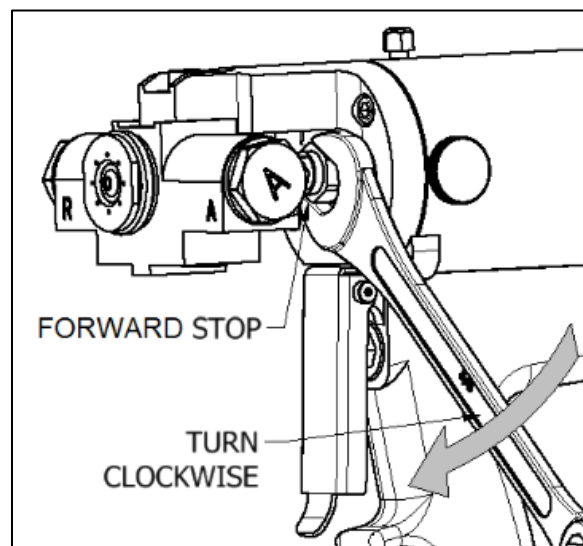

Figure 9: Turn Forward Stop Clockwise

13. For pour applications, skip this step. For spray applications, install the **PCD** onto the **Front Packing Retainer** and screw the **PCD Retainer** and **Air Cap** (See Figure 10).

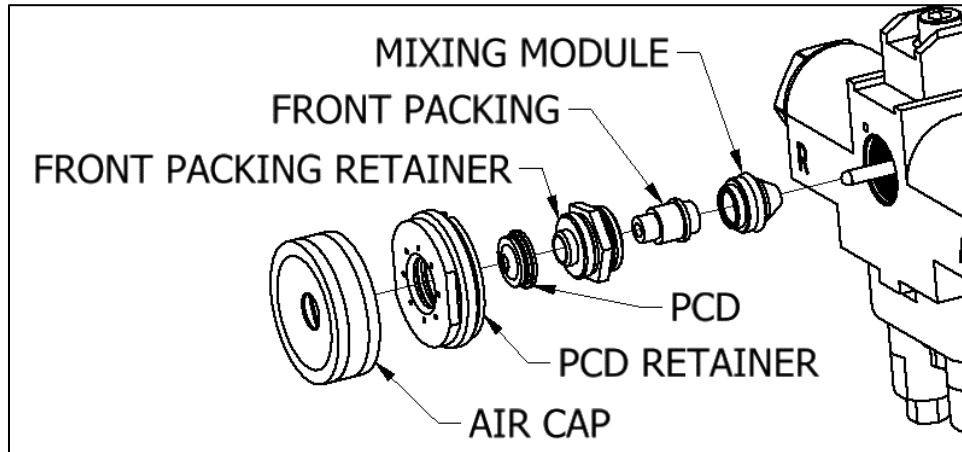

Figure 10: Spray Configuration

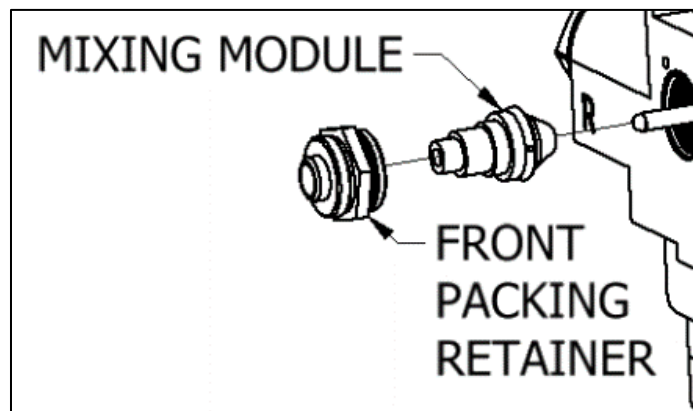

Figure 11: Pour Configuration

14. Adjust **Valving Rod** per the procedure on page 12.

Valving Rod Adjustment

CAUTION! Failure to perform Valving Rod Adjustment Procedure properly may cause pattern deformation and damage to Valving rod and/or PCD.

1. Set the **Safety Stop** to the **LOCKED** position.
2. Ensure the **Manual Valves** are **CLOSED** by turning them to the full clockwise position.

CAUTION! Excessive force closing or opening Manual Valves may result in damage to the Manual Valves and/or Coupling Block.

3. Remove **Coupling Block** from **Gun**
4. Clean **Gun** per Daily Cleaning Procedure on page 16.
5. Connect the **Air Hose** to the **Supply Air Hose**.
6. Loosen the **Rear Packing Nut**.
7. Loosen **Forward Stop Clamp Screw** at top of **Cylinder**.

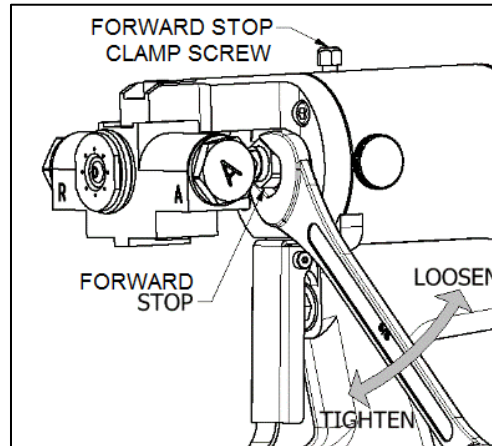

Figure 12: Valving Rod Adjustment

8. Turn **Forward Stop** fully counterclockwise to loosen.
9. Slowly tighten **Forward Stop** by turning clockwise until snug resistance is felt. Then, loosen 1/6 of a turn (one wrench flat).
10. Hand-tighten **Forward Stop Clamp Screw**. If **Forward Stop Clamp Screw** bottoms out before resistance is felt, replace the plastic pellet in the hole.
11. Tighten **Rear Packing Nut** until finger tight and turn with wrench one half turn, then adjust as necessary.

Rear Packing Nut Adjustment

1. **Rear Packing Nut** (see Figure 13) should be initially installed finger-tight, then turned with a ½" wrench one half turn.

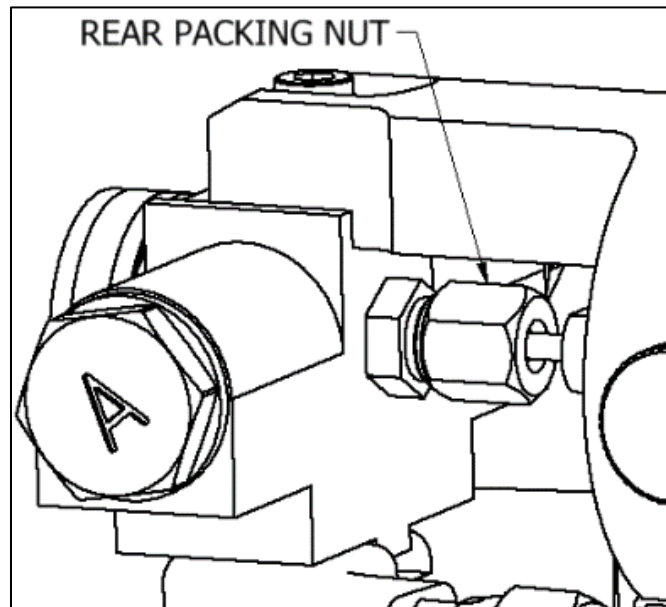

Figure 13: Rear Packing Nut

2. If excessive leaking occurs during operation, adjust **Rear Packing Nut** with a ½" wrench as necessary to prevent leakage. Do not overtighten!

CAUTION! *Overtightening the rear packing nut can damage the rear packing and/or cause the Valving Rod to move slowly.*

3. If leakage continues, replace **Rear Packing** (200396).

Air Cap Valve Adjustment

1. Experiment with spraying.
2. If excessive overspray is observed and/or spray pattern is not satisfactory, decrease air flow to **Air Cap** by turning **Air Cap Adjustment Valve** clockwise (see Figure 14).
3. If mixed material builds up on **PCD**, increase air flow to **Air Cap** by turning **Air Cap Adjustment Valve** counter-clockwise.

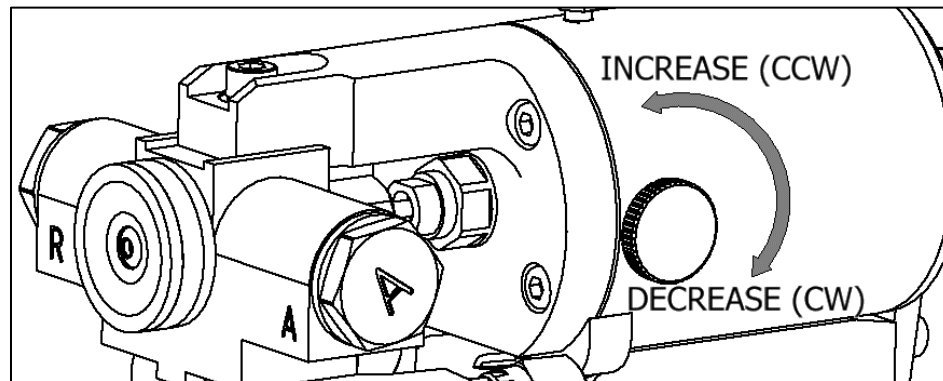

Figure 14: Air Cap Valve Adjustment

Shutdown Procedure

1. Set the **Safety Stop** to the **LOCKED** position and **CLOSE** the **Manual Valves** by turning them to the full clockwise position using the supplied 5/16" **Nut Driver**.

CAUTION! Excessive force closing or opening **Manual Valves** may result in damage to the **Manual Valves** and/or **Coupling Block**.

2. Disconnect the air supply.
3. Remove the **Coupling Block** and clean the **Gun** per the Daily Cleaning Procedure (see page 16).

MAINTENANCE

To obtain maximum performance from your **PX-7** Gun, it is necessary to periodically perform certain maintenance operations

WARNING! *Before proceeding with any maintenance work on the PX-7 Gun, trigger the gun to remove internal material pressure, ensure the Manual Valves are CLOSED, ensure the Gun Lock is in the LOCKED position, and SHUT OFF/DISCONNECT the air supply. It is recommended to remove the Gun from the Coupling Block.*



To prevent possible injury caused by incorrect handling of the materials and solvents used in the process, carefully read the Safety Data Sheet (SDS) provided by your supplier.



To avoid damage caused by the impact of pressurized fluids, do not open any connection or perform maintenance work on components subject to pressure until the pressure has been completely eliminated.



Use suitable protection when operating, maintaining or being present in the area where the equipment is functioning. This includes, but is not limited to, the use of protective goggles, gloves, shoes and safety clothing and breathing equipment.



The equipment includes components that reach high temperatures and can cause burns. Hot parts of the equipment must not be handled or touched until they have cooled completely.



The equipment sprays high pressure fluids that can lead to fluid being injected under the skin or eyes. Severe injury could be incurred. Proper personal protective equipment should be used in conjunction with training and situational awareness of all personnel on the job.

Daily Cleaning Procedure

1. Remove the **Coupling Block** and install the **Flush Block**.

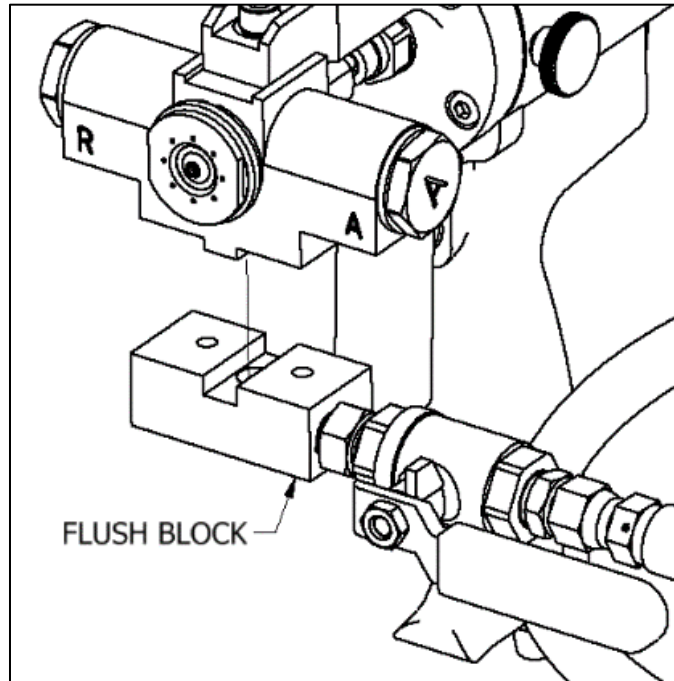

Figure 15: Flush Block Installation

2. Ensure the **Flush Tank** is pressurized (see Flush Tank manual for instructions).
3. Trigger the **Gun** into a waste container until the solvent or gun cleaner has completely flushed the system.
4. Remove the **Air Cap**, **PCD Retainer**, and **PCD**.
5. Repeat Flush procedure.
6. Disconnect the **Flush Block**, lock **Safety Stop**, and disconnect **Air Supply**.

CAUTION! Never use air tool oil to lubricate gun. The use of air tool oil can cause the O-rings to swell and will void the warranty.

7. Inspect and clean **Gun Block, Air Cap, PCD Retainer, PCD, Mixing Module, Screen Screws, Screens, and Check Valves.**

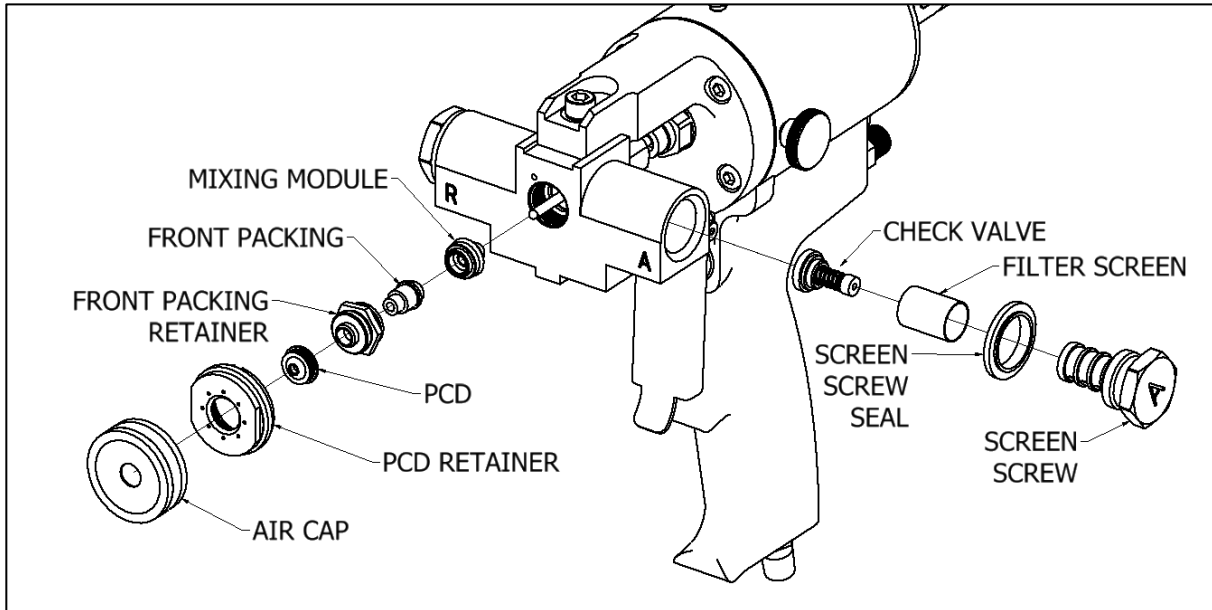

Figure 16: Clean Parts

8. Use supplied **PMC Lubriplate Grease** on O-rings and threads.

CAUTION! *Never use air tool oil to lubricate gun. The use of air tool oil can cause the O-rings to swell and will void the warranty.*

TROUBLE SHOOTING GUIDE

PROBLEM	POSSIBLE CAUSE	SOLUTION
Material does not spray when Gun is triggered	Lock is in "Locked" position	Unlock gun
	Air supply is not on	Turn on air supply
	Manual Valves CLOSED	OPEN
	Mixing Module Inlet Orifices plugged	Clean
	Screens are clogged	Clean
	Screen Screw Check Valve plugged or stuck	Replace
Valving Rod moves slowly	Air Tool Oil was used	Replace O-rings
	Insufficient Gun air pressure (minimum 90 psi)	Ensure 90 psi air pressure
	Rear Packing Nut too tight	Adjust (see Page 13)
	Air Passages plugged	Clean
	Air Manifold requires service	Rebuild
	Piston Assembly requires service	Rebuild
	Worn Module	Replace
Pattern deformation	Incorrect chemical temperature	See Proportioner Manual
	Valving Rod requires adjustment	Adjust (see Page 12)
	Mixing Module and/or PCD dirty	Inspect and clean
	Worn Module	Replace
Material spray pressure imbalance	Material temperatures not as recommended	Adjust
	Dirty filter screens	Replace
	Screen Screw Check Valve plugged or stuck	Replace
	Mixing Module Inlet Orifices plugged	Clean
	Worn Module	Replace
Chemicals leak from Gun Block	Coupling Block Gaskets damaged or missing	Replace
	Rear/Front Packing, or Mixing Module worn	Replace
Excessive overspray	Material temperatures and/or spray pressures not as recommended by material supplier	Adjust, see Proportioner Operating Manual
	Too much air flow to Air Cap	Adjust Air Cap Valve
Buildup of material on PCD	Insufficient air flow to Air Cap	Adjust Air Cap Valve
	Plugged air passages in bridge and Gun Block	Clean
Air leakage from Handle	Trigger Valve O-rings damaged	Replace
	Air Cylinder O-rings damaged	Replace

REFERENCE GUIDE

Spray Module Kits								
GUN ITEM NO.	MODULE KIT ITEM NO.	MODULE	DRILL NO.		PCD NO.	NO. OF PORTS	ISO PORT DIA. (in)	RESIN PORT DIA. (in)
200561	200547	#1 ROUND	67		90	8	0.0320	0.0320
200562	200549	#3 ROUND	74	77	70	8	0.0225	0.0180
200565	200551	#5 ROUND	74	70	70	8	0.0225	0.0280
200567	200553	#10 FLAT	64		210	4	0.0360	
200569	200555	# 16 ROUND	70		90	8	0.0280	
200570	200556	#22 ROUND	74		70	8	0.0225	
201100	200553	#10 FLAT	64		TP-100	4	0.0360	

Pour Module Kits							
GUN ITEM NO.	MODULE KIT ITEM NO.	MODULE	DRILL NO.	FRONT PACKING	NO. OF PORTS	ISO PORT DIA. (in)	RESIN PORT DIA. (in)
200572	200558	A3 POUR	61	--	2	0.0390	
200573	200559	A5 POUR	67	--	2	0.0320	
-	202672	A3 POUR	61	200397	2	0.0390	
-	202673	A5 POUR	67	200397	2	0.0320	
-	202674	42/42 POUR	59	200397	2	0.0420	

PCD Sizes		
ITEM NO.	PCD NO.	DIA. (in)
200485	PCD 90	0.089
200487	PCD 70	0.073
200727	PCD 210	0.027 x 0.099
201099	TP-100	0.018 x 0.103

Module Drills		
PART NUMBER	DRILL NO.	DIA. (in)
GU-03021	59	0.0420
GU-03032	61	0.0390
200544	64	0.0360
200539	67	0.0320
GU-03031	70	0.0280
GU-03055	74	0.0225
200540	77	0.0180

Torque Specifications

TORQUE SPECIFICATIONS		
PART NUMBER	DESCRIPTION	RECOMMENDED TORQUE
200376	MOUNTING BOLT, BRIDGE, PX-7	80 – 90 in-lbs
200507	PIPE PLUG, 1/16, NPT , STEEL	2-3 T.F.F.T.*
200456	FRONT PACKING RETAINER, PX-7	225 in-lbs
200508	PIPE PLUG, 1/8, NPT , STEEL	2-3 T.F.F.T.*
201582	SHCS, #10-32 X 0.625, 18-8 SS	30 – 40 in-lbs
TN-04193	COUPLING BLOCK MOUNTING SCREW	160 – 170 in-lbs

* T.F.F.T = Turns From Finger Tight

Flush Tanks

Optional 2.5 Gallon Flush Tank (200426) and 1 QT Mini Flush Tank (200216) shown.

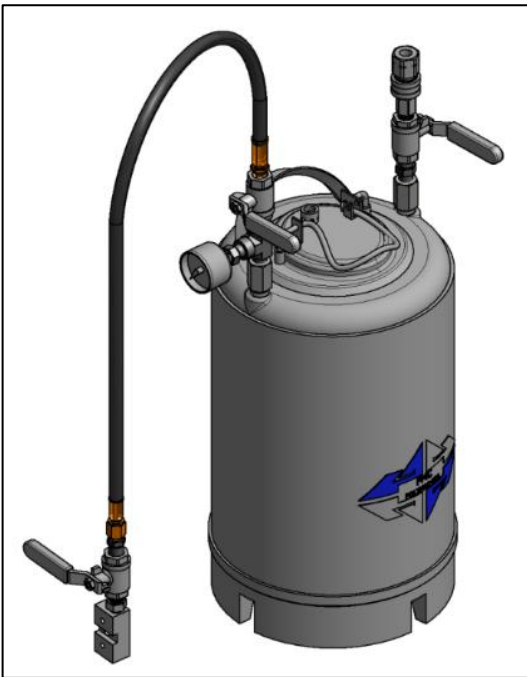

Figure 17: 2.5 Gallon Flush Tank (200426)

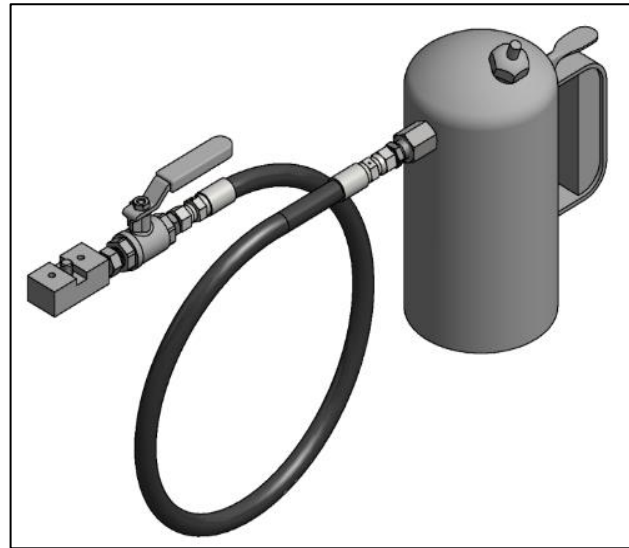

Figure 18: 1 QT Mini Flush Tank (200216)

FLUSH TANKS	
2.5 Gallon Flush Tank	1 QT Mini Flush Tank
200426 – Solvent Flush Kit, 2.5 Gal, AP	200216 – Solvent Flush Kit, Quart, AP
200427 – Solvent Flush Kit, 2.5 Gal, F-AP	200217 – Solvent Flush Kit, F-AP

Refer to flush tank manuals (MN-04023 & MN-04025) for further details.

PARTS IDENTIFICATION

Gun Assembly

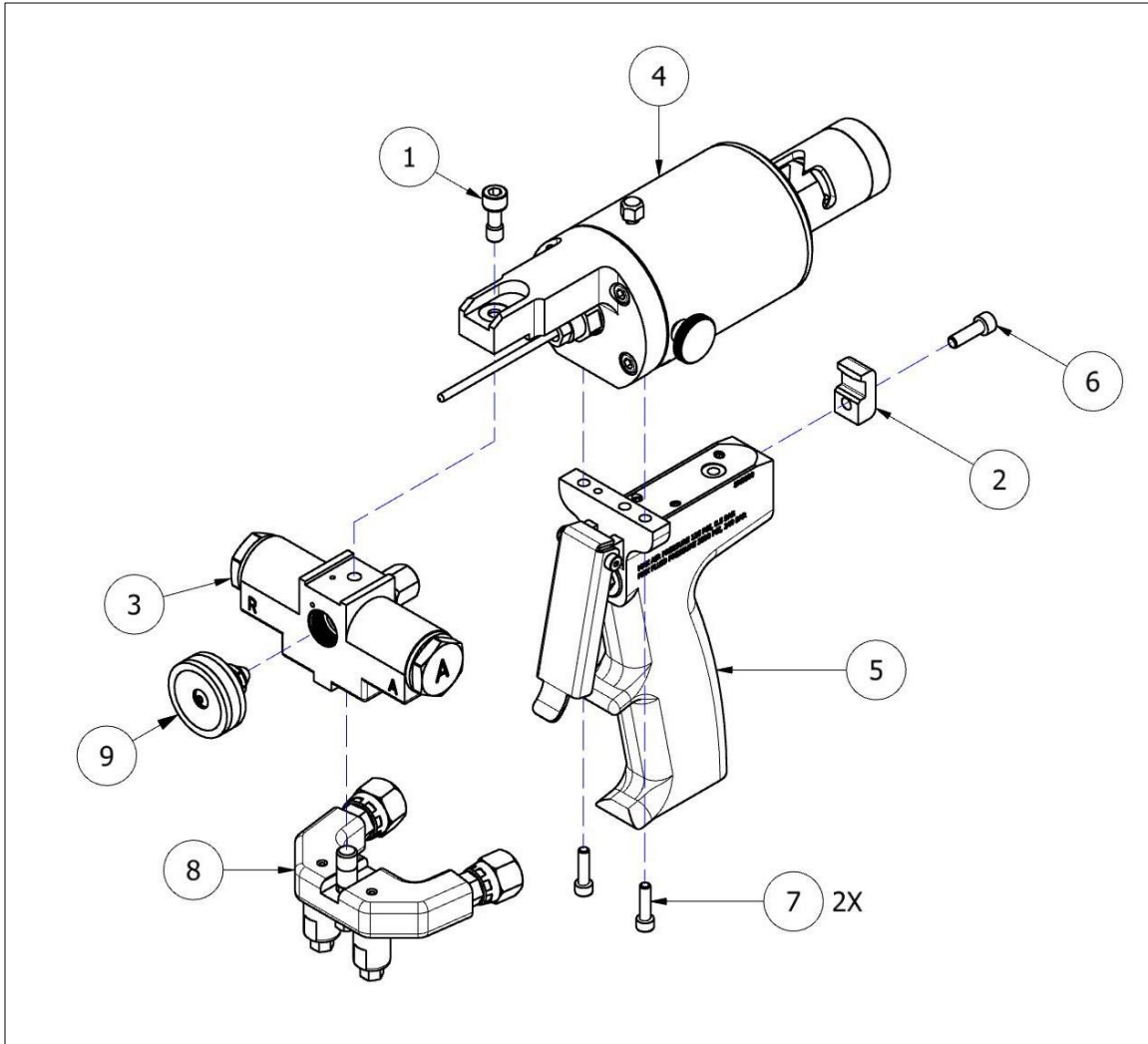

GUN ASSEMBLY			
ITEM	PART NUMBER	DESCRIPTION	QTY
1	200376	MOUNTING BOLT, BRIDGE, PX-7	1
2	200438	CYLINDER CLAMP, PX-7	1
3	200468	GUN BLOCK ASSY, PX-7	1
4	200469	AIR PISTON ASSEMBLY	1
5	200470	HANDLE ASSEMBLY, PX-7	1
6	201582	SHCS, #10-32 X 0.625, 18-8 SS	1
7	201894	SHCS, 8-36 X 0.625, SS	2
8	GU-04001	COUPLING BLOCK ASSEMBLY	1
9	-	MODULE COMPONENTS: SEE PGS 28 & 29	-

Gun Block Assembly

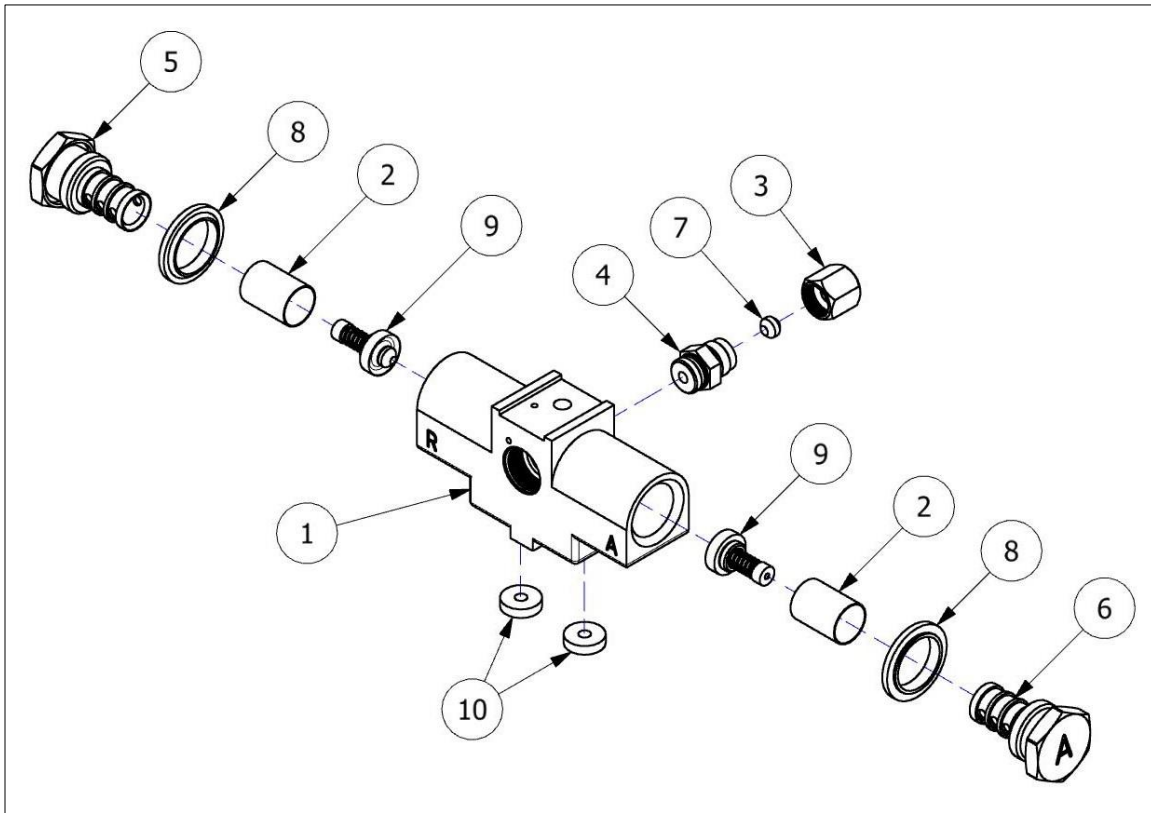

GUN BLOCK ASSEMBLY 200468			
ITEM	PART NUMBER	DESCRIPTION	QTY
1	200361	GUN BLOCK, PX-7	1
2	200381	SCREEN, 60 MESH, PX-7	2
3	200391	REAR PACKING NUT, PX-7	1
4	200392	REAR PACKING RETAINER, PX-7	1
5	200393	SCREEN SCREW, R-SIDE, PX-7	1
6	200394	SCREEN SCREW, A-SIDE, PX-7	1
7	200396	REAR PACKING, PX-7	1
8	200442	SCREEN SCREW SEAL	2
9	200443	CHECK VALVE ASSEMBLY, PX-7	2
10	200444	GASKET, PTFE	2

Air Cylinder Assembly

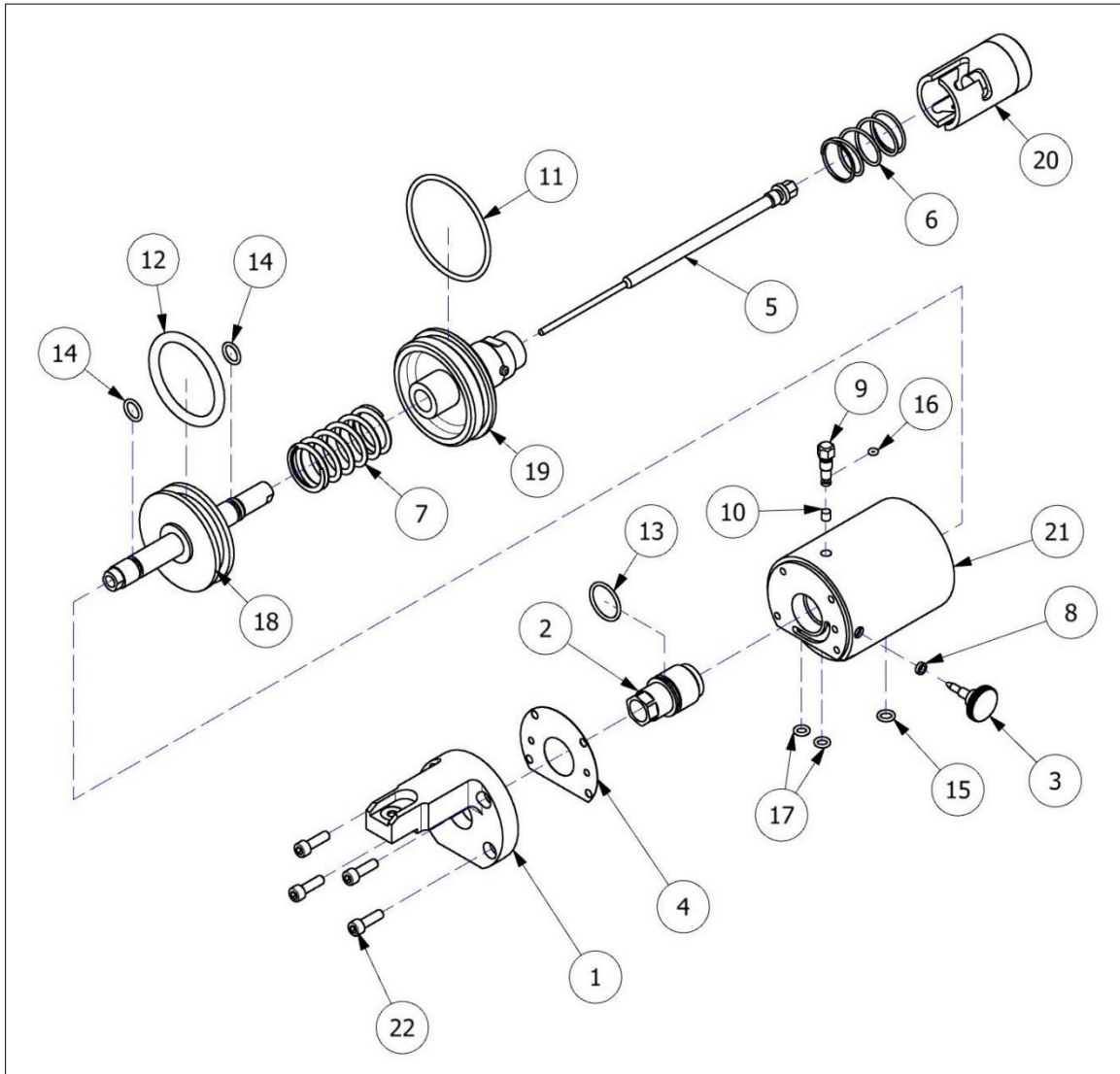

AIR CYLINDER ASSEMBLY 200469			
ITEM	PART NUMBER	DESCRIPTION	QTY
1	200362	BRIDGE, PX-7	1
2	200371	BEARING, CYLINDER, PX-7	1
3	200372	NEEDLE VALVE, CYLINDER, PX-7	1
4	200375	GASKET, CYLINDER, PX-7	1
5	200377	VALVING ROD, PX-7	1
6	200378	SPRING, 0.970 O.D. X .063 W.D. X 1.00 LG	1
7	200379	SPRING, 1.095 O.D X 0.112 W.D. X 2.00 LG	1
8	200380	GASKET, NEEDLE VALVE, PX-7	1
9	200382	PLUG, CYLINDER, PX-7	1
10	200383	LOCK, BEARING, PX-7	1
11	200457	O-RING, VITON, -140	1
12	200458	O-RING, VITON, -328	1
13	200459	O-RING, VITON, -018	1
14	200460	O-RING, VITON, -012	2
15	200461	O-RING, VITON, -010	1
16	200462	O-RING, VITON, -004	1
17	200463	O-RING, VITON, -009	2
18	200471	PISTON ASSEMBLY, PX-7	1
19	200472	CYLINDER END CAP ASSEMBLY, PX-7	1
20	200473	TWO POSITION STOP ASSEMBLY, PX-7	1
21	200717	CYLINDER, PX-7	1
22	201582	SHCS, #10-32 X 0.625, 18-8 SS	4

Handle Assembly

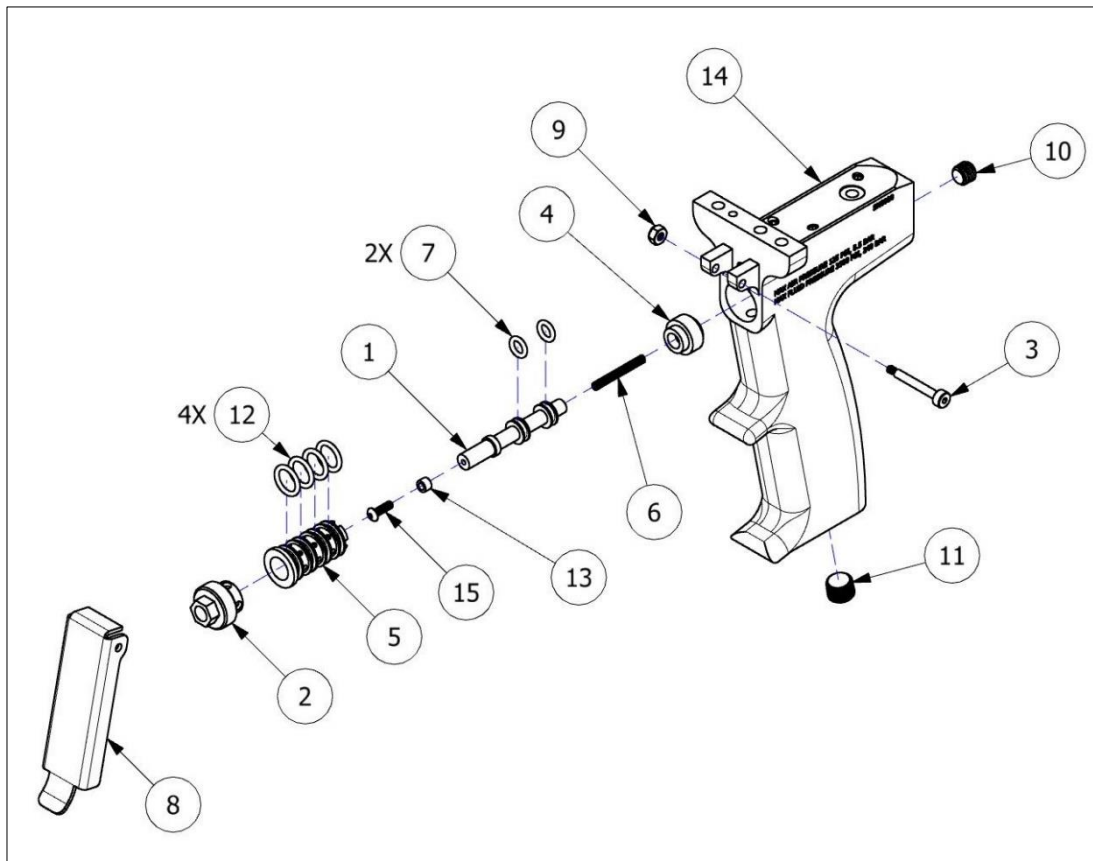

HANDLE ASSEMBLY 200470			
ITEM	PART NUMBER	DESCRIPTION	QTY
1	200435	SPOOL VALVE, PX-7	1
2	200436	VALVE RETAINER NUT, PX-7	1
3	200437	TRIGGER MOUNTING SCREW, PX-7	1
4	200439	SPRING SEAT, PX-7	1
5	200440	SPOOL LINER, PX-7	1
6	200441	AIR VALVE SPRING	1
7	200463	O-RING, VITON, -009	2
8	200464	TRIGGER, PX-7	1
9	200467	LOCKNUT, HEX, 5-40, SS	1
10	200507	PIPE PLUG, 1/16, NPT , STEEL	1
11	200508	PIPE PLUG, 1/8, NPT, STEEL	1
12	200513	O-RING,VITON,9.25 x 1.78MM	4
13	200705	SPACER	1
14	202306	SUB ASSY, HANDLE W/ SET SCREWS, PX-7	1
15	202307	BHCS, #4-40 X 0375, 18-8 SS	1

Coupling Block Assembly

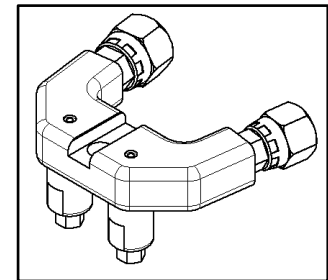
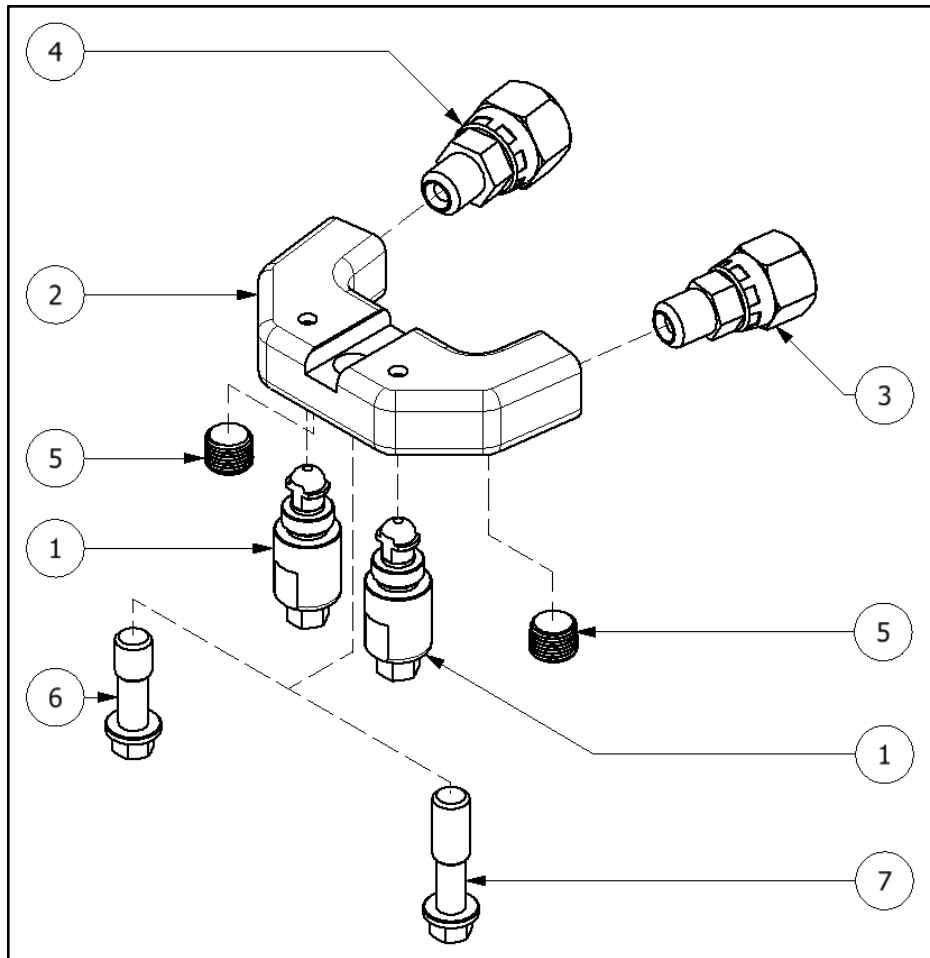

STANDARD ORIENTATION

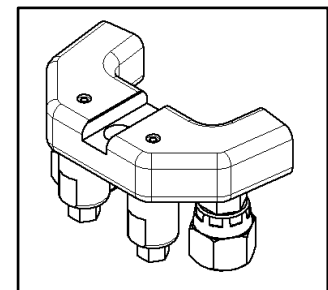

OPTIONAL ORIENTATION

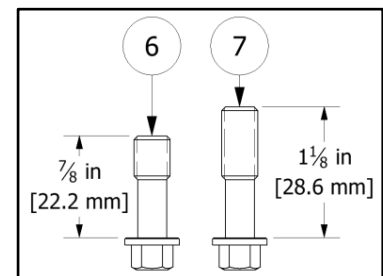

MOUNTING SCREWS

COUPLING BLOCK ASSEMBLY

GU-04001

ITEM	PART NUMBER	DESCRIPTION	QTY
1	GU-020	MANUAL VALVE ASSY	2
2	GU-04001-01	BODY, COUPLING BLOCK	1
3	RA-00005A	1/8 NPT x #5 JIC SWIVEL	1
4	RA-00006A	1/8 NPT X #6 JIC SWIVEL	1
5	TN-04192	PIPE PLUG, 1/8 NPT, STL	2
6 ¹	TN-04193	COUPLING BLOCK MOUNTING SCREW	1
7 ²	TN-04197	COUPLING BLOCK STABILIZER MOUNTING SCREW	1

¹ TN-04193 is used for AP-3, AP-EX, and PX-7 gun models.

² TN-04197 is used for AP-2 gun models only.

Manual Valve Assembly

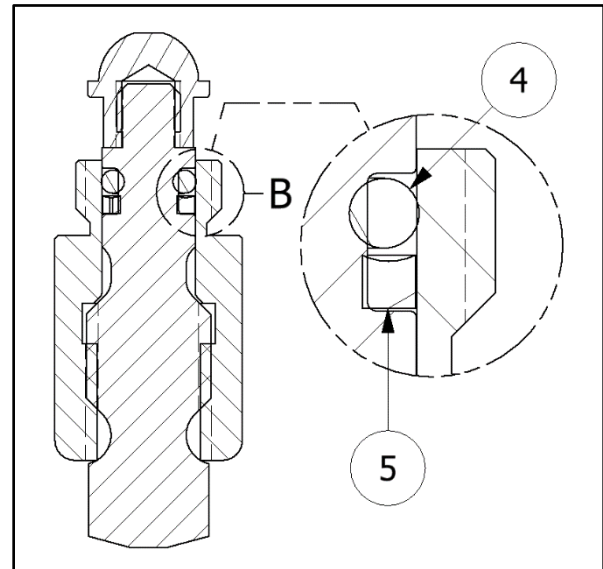
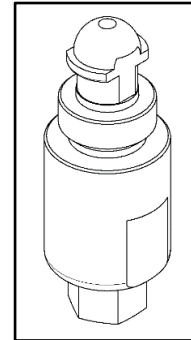
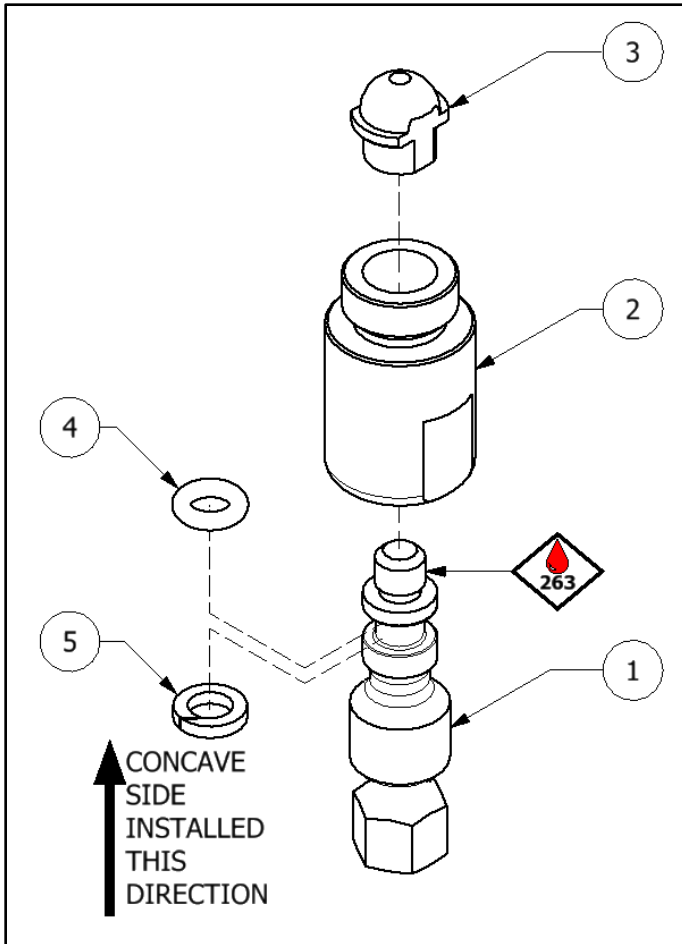

 = Apply Red Loctite 263 or similar to indicated threads.

Note: Orientation of the Back-Up Ring is critical. The concave side must be aligned with the o-ring as shown above when it is installed.

MANUAL VALVE ASSEMBLY

GU-020

ITEM	PART NUMBER	DESCRIPTION	QTY
1	GU-021	MANUAL VALVE, VALVE STEM	1
2	GU-022	MANUAL VALVE, HOUSING	1
3	GU-023	MANUAL VALVE, SEAT	1
4	OR-015	O-RING, AFLAS, -007	1
5	OR-016	BACK-UP RING, -007, VITON	1

Spray Module Components

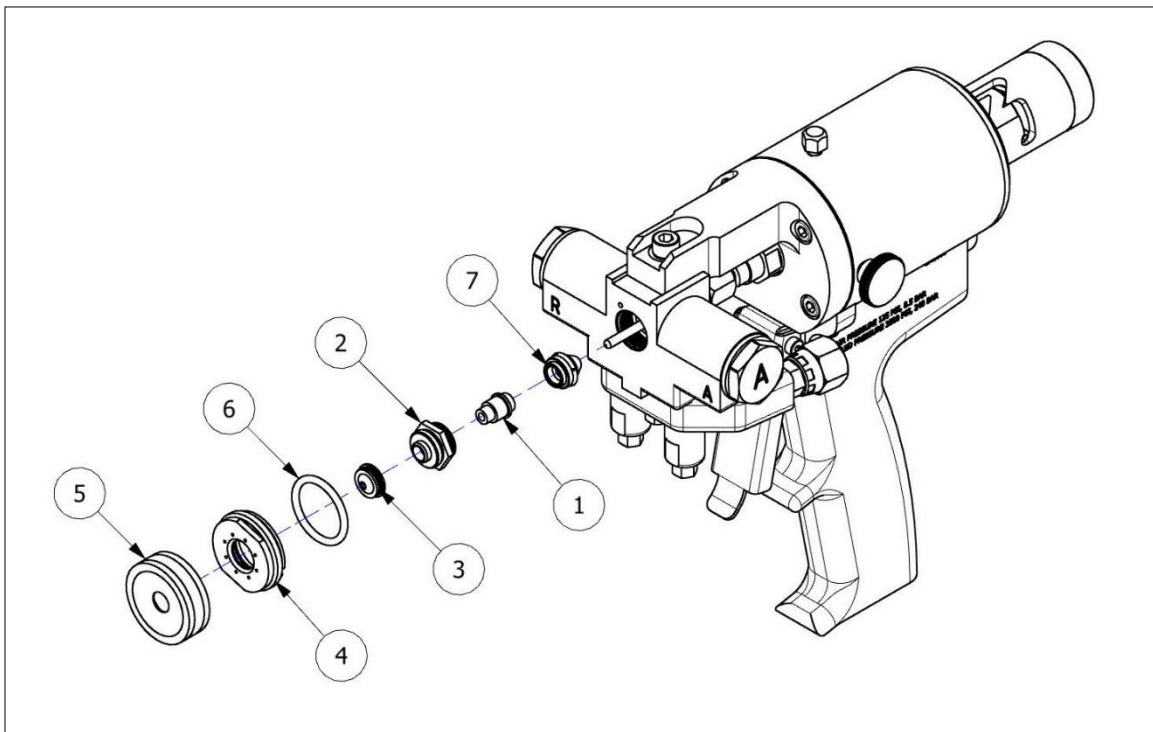

See page 19 for Spray Module and PCD data.

SPRAY MODULE COMPONENTS			
ITEM	PART NUMBER	DESCRIPTION	QTY
1	200397	FRONT PACKING, PX-7	1
2	200456	FRONT PACKING RETAINER, PX-7	1
3	See page 19	PCD	1
4	200493	PCD RETAINER, PX-7	1
5	200494	AIR CAP, PX-7	1
6	200502	O-RING, AFLAS, -118	1
7	See page 19	SPRAY MODULE	1

Pour Module Components

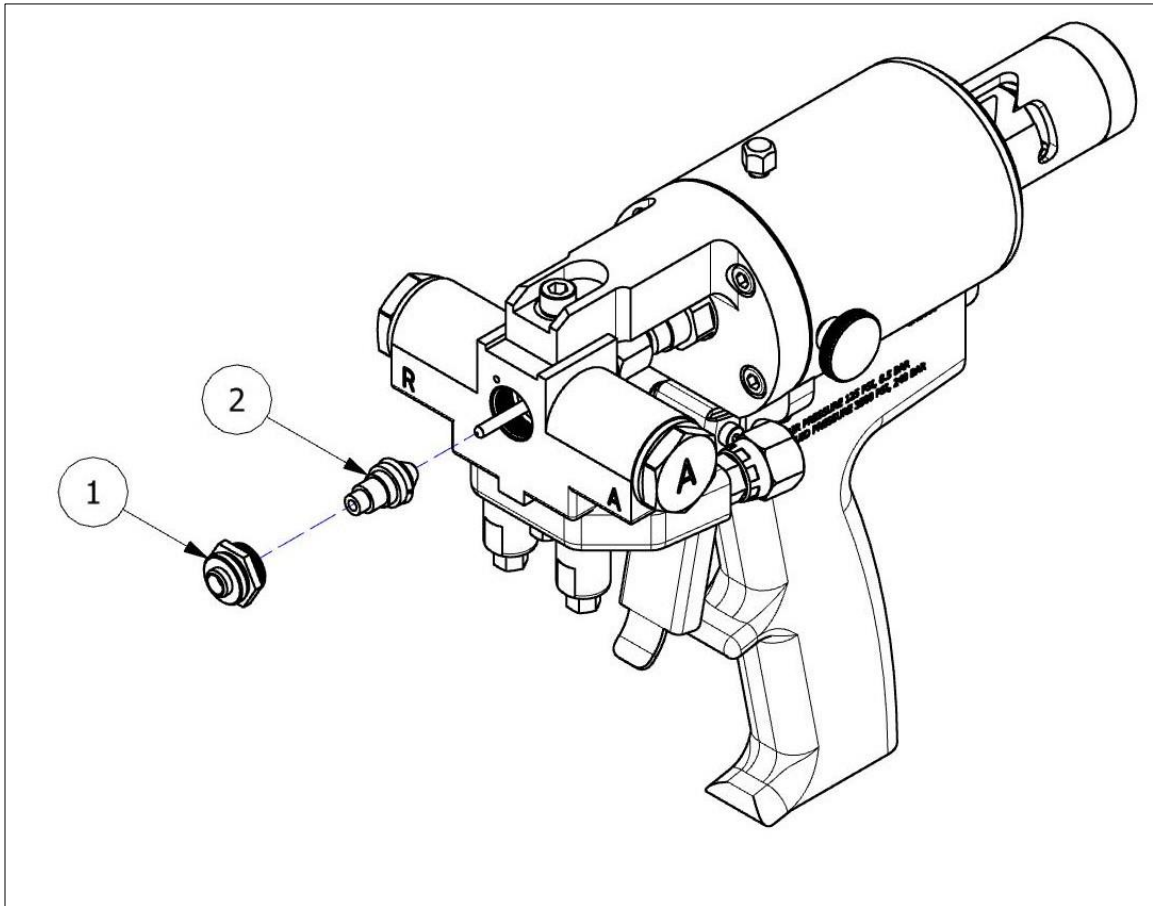

See page 19 for Pour Module data.

POUR MODULE COMPONENTS			
ITEM	PART NUMBER	DESCRIPTION	QTY
1	200456	FRONT PACKING RETAINER, PX-7	1
2	See page 19	POUR MODULE	1

SPARE PARTS & REBUILD KITS

PX-7 Tool Kit

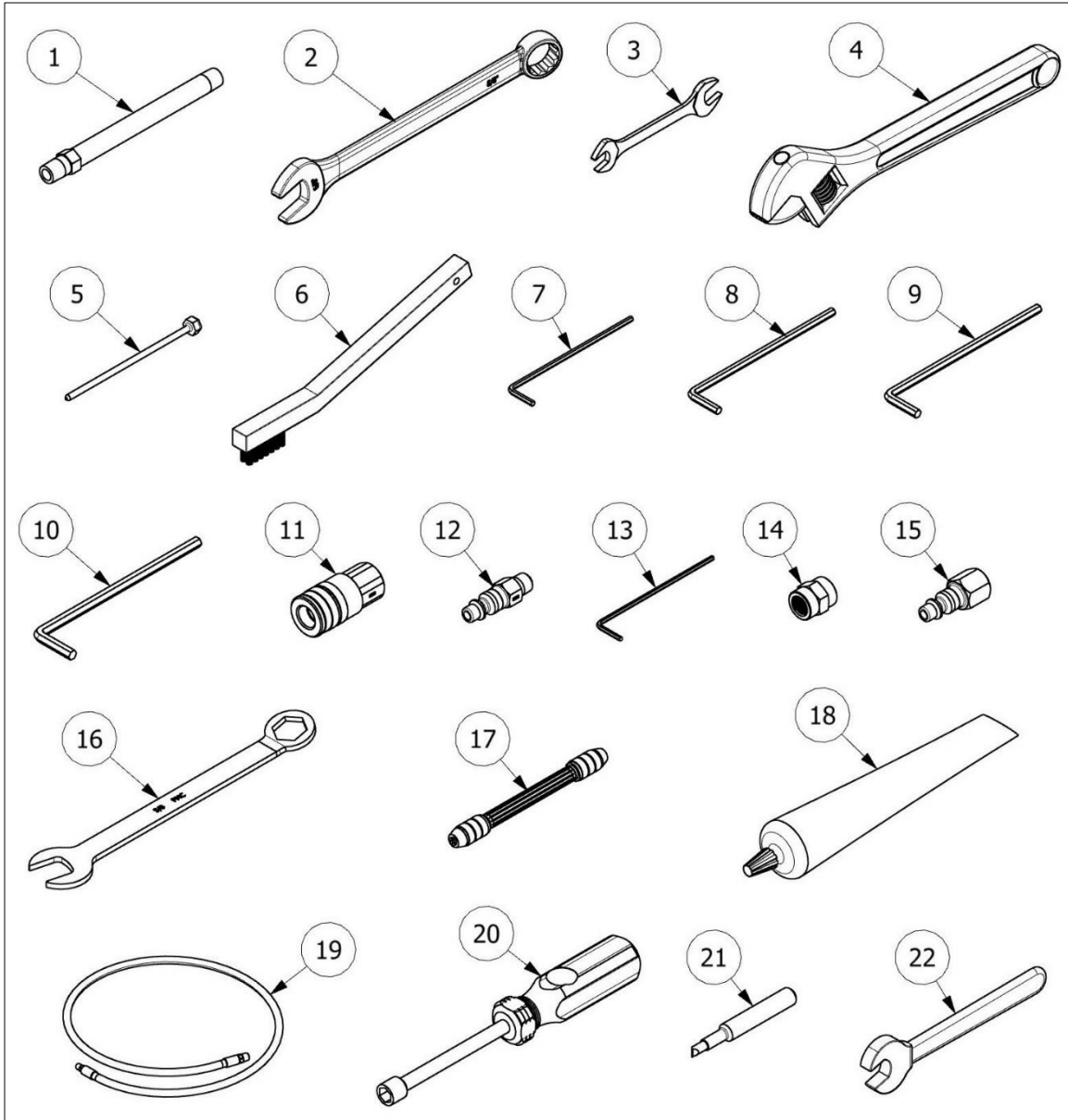

PX-7 Gun Tool Kit 200575			
ITEM	PART NUMBER	DESCRIPTION	QTY
1	200454	Pipe Nipple, PX-7	1
2	200576	5/8" Combination Wrench	1
3	200577	5/16 x 3/8" Open End Wrench	1
4	200578	Adjustable Wrench	1
5	200579	Air Valve Tool	1
6	200580	Cleanout Brush	1
7	200581	3/32" Allen Wrench	1
8	200582	9/64" Allen Wrench	1
9	200583	5/32" Allen Wrench	1
10	200584	3/16" Allen Wrench	1
11	200585	Quick Connect, Female	1
12	200586	Quick Connect Fitting, Male	1
13	200609	5/64" Allen Wrench	1
14	200620	Fitting, 1/8 NPT Coupling	1
15	200622	Fitting, 1/4 FNPT X 1/4 QD	1
16	201116	5/8" Wrench	1
17	GP-00101	Double Ended Pin Vise	1
18	GP-LUBEGREASE	Lubriplate Grease	1
19	GU-04019	Air Hose, 1/8 NPT	1
20	TL-04001	5/16 Spintite, Nut Driver	1
21	TL-10	Check Valve Removal Tool	1
22	TL-21	1/2" Black Open End Wrench	1

Cylinder/Piston Rebuild Kit

200615

PART NUMBER	DESCRIPTION	QTY
200375	GASKET: CYLINDER	1
200380	GASKET: NEEDLE VALVE	1
200457	O-RING #140	1
200458	O-RING #328	1
200459	O-RING #018	1
200460	O-RING #012	2
200461	O-RING #010	1
200462	O-RING #004	1
200463	O-RING #009	2
GP-LUBEGREASE	GREASE	1

Trigger Rebuild Kit

200616

PART NUMBER	DESCRIPTION	QTY
200435	SPOOL VALVE	1
200440	LINER	1
200441	SPRING	1
200463	O-RING #009	2
200513	O-RING #013	4
GP-LUBEGREASE	GREASE	1

Gun Block Rebuild Kit, PX-7

200617

PART NUMBER	DESCRIPTION	QTY
200381	SCREEN, 60 MESH, PX-7	2
200393	SCREEN SCREW, R-SIDE, PX-7	1
200394	SCREEN SCREW, A-SIDE, PX-7	1
200396	REAR SEAL PACKING, PX-7	1
200442	SCREEN SCREW SEAL, PX-7	2
200443	CHECK VALVE ASSEMBLY, PX-7	2
200444	COUPLING BLOCK GASKET, PX-7	2
200502	O-RING, AFLAS, -118	1

Screen Screw Kit, A-Side, PX-7 200618

PART NUMBER	DESCRIPTION	QTY
200381	SCREEN, PX-7	2
200394	SCREEN SCREW, A-SIDE, PX-7	1
200442	SCREEN SCREW SEAL	2
200443	CHECK VALVE ASSEMBLY, PX-7	2

Screen Screw Kit, R-Side, PX-7 200619

PART NUMBER	DESCRIPTION	QTY
200381	SCREEN, PX-7	2
200393	SCREEN SCREW, R-SIDE, PX-7	1
200442	SCREEN SCREW SEAL	2
200443	CHECK VALVE ASSEMBLY, PX-7	2

Screen Kits

KIT NUMBER	DESCRIPTION	QTY
200625	SCREEN KIT 60 (STANDARD WITH POUR GUN)	10
200645	SCREEN KIT 40	10
200646	SCREEN KIT 80 (STANDARD WITH SPRAY GUN)	10

1/4" Unheated Stainless Steel Hose Assy. MA-41

PART NUMBER	DESCRIPTION
MA-43	AIR HOSE, 22"
MA-41A	REPLACEMENT HOSE, "A" SIDE
MA-41R	REPLACEMENT HOSE, "R" SIDE



Figure 19: Kit MA-41 Shown on PX-7

PX-7 Spare Parts Kits									
KIT PART NUMBER:		200626	200627	200628	200629	200630	202772	202773	202774
		Modules							
PART NUMBER	DESCRIPTION	A3	A5	#1	#3	#5	#10	#16	#22
200377	VALVING ROD, PX-7	1	1	1	1	1	1	1	1
200381	SCREEN, 60 MESH, PX-7	4	4	-	-	-	-	-	-
200396	REAR SEAL PACKING, PX-7	1	1	1	1	1	1	1	1
200442	SCREEN SCREW SEAL, PX-7	2	2	2	2	2	2	2	2
200443	CHECK VALVE ASSY, PX-7	2	2	2	2	2	2	2	2
200444	COUPLING BLOCK GASKET, PX-7	2	2	2	2	2	2	2	2
200547	MOD KIT,#1 RD,PX-7 (W/DRILLS)	-	-	1	-	-	-	-	-
200549	MOD KIT,#3 RD,PX-7 (W/DRILLS)	-	-	-	1	-	-	-	-
200551	MOD KIT,#5 RD,PX-7 (W/DRILLS)	-	-	-	-	1	-	-	-
200553	MOD KIT,#10 FT,PX-7 (W/DRILLS)	-	-	-	-	-	1	-	-
200555	MOD KIT,#16 RD,PX-7 (W/DRILLS)	-	-	-	-	-	-	1	-
200556	MOD KIT,#22 RD,PX-7 (W/DRILLS)	-	-	-	-	-	-	-	1
200558	MOD KIT,A3,PX-7 (W/DRILLS)	1	-	-	-	-	-	-	-
200559	MOD KIT,A5,PX-7 (W/DRILLS)	-	1	-	-	-	-	-	-
200611	SCREEN, 80 MESH, PX-7	-	-	4	4	4	4	4	4
200615	CYL./PISTON REBUILD KIT, PX-7	1	1	1	1	1	1	1	1
200616	TRIGGER REBUILD KIT, PX-7	1	1	1	1	1	1	1	1
GU-020	MANUAL VALVE ASSY	2	2	2	2	2	2	2	2
KT-020	MANUAL VALVE SOFTWARE KIT	1	1	1	1	1	1	1	1

Kit List			
KIT PART NUMBER	ITEM PART NUMBER	DESCRIPTION	ITEM QTY
200547-200559	MIXING MODULE KIT (W/ DRILLS) (SEE CHART PG. 19)		
200618	SCREEN SCREW KIT, A-SIDE, PX-7		
	200381	SCREEN, PX-7	2
	200394	A-SIDE SCREEN SCREW, PX-7	1
	200442	SCREEN SCREW SEAL, PX-7	2
	200443	CHECK VALVE ASSY, PX-7	2
200619	SCREEN SCREW KIT, R-SIDE, PX-7		
	200381	SCREEN, PX-7	2
	200393	R-SIDE SCREEN SCREW, PX-7	1
	200442	SCREEN SCREW SEAL, PX-7	2
	200443	CHECK VALVE ASSY, PX-7	2
200623	CHECK VALVE KIT, PX-7 (QTY 10)		
	200443	CHECK VALVE ASSY, PX-7	10
200624	COUPLING BLOCK GASKET KIT (QTY 2)		
	200444	COUPLING BLOCK GASKET	2
200625	SCREEN KIT 60 (QTY 10) (STANDARD WITH POUR GUN)		
	200381	SCREEN, PX-7	10
200645	SCREEN KIT 40 (QTY 10)		
	200610	SCREEN, 40, PX-7	10
200646	SCREEN KIT 80 (QTY 10) (STANDARD WITH SPRAY GUN)		
	200611	SCREEN, 80, PX-7	10
200647	TRIGGER MT SCREW KIT, PX-7		
	200437	SHOULDER BOLT, PX-7	1
	200467	LOCKNUT, PX-7	1
200648	REAR SEAL PACKING KIT, PX-7 (QTY 5)		
	200396	REAR SEAL PACKING, PX-7	5
200649	SCREEN SCREW SEAL KIT (QTY 2)		
	200442	SCREEN SCREW SEAL, PX-7	2
201149	FRONT PACKING KIT (QTY 5)		
	200397	FRONT PACKING, PX-7	5
202369	SPOOL VALVE, ASSEMBLY, PX-7		
	200435	SPOOL VALVE, PX-7	1
	200705	TRIGGER SPACER	1
	202307	BHCS, #4-40 X 0.375, 18-8 SS	1

SLAB JACKING & CONCRETE POURING COMPONENTS

PX-7 Slab Jack Starter Kit

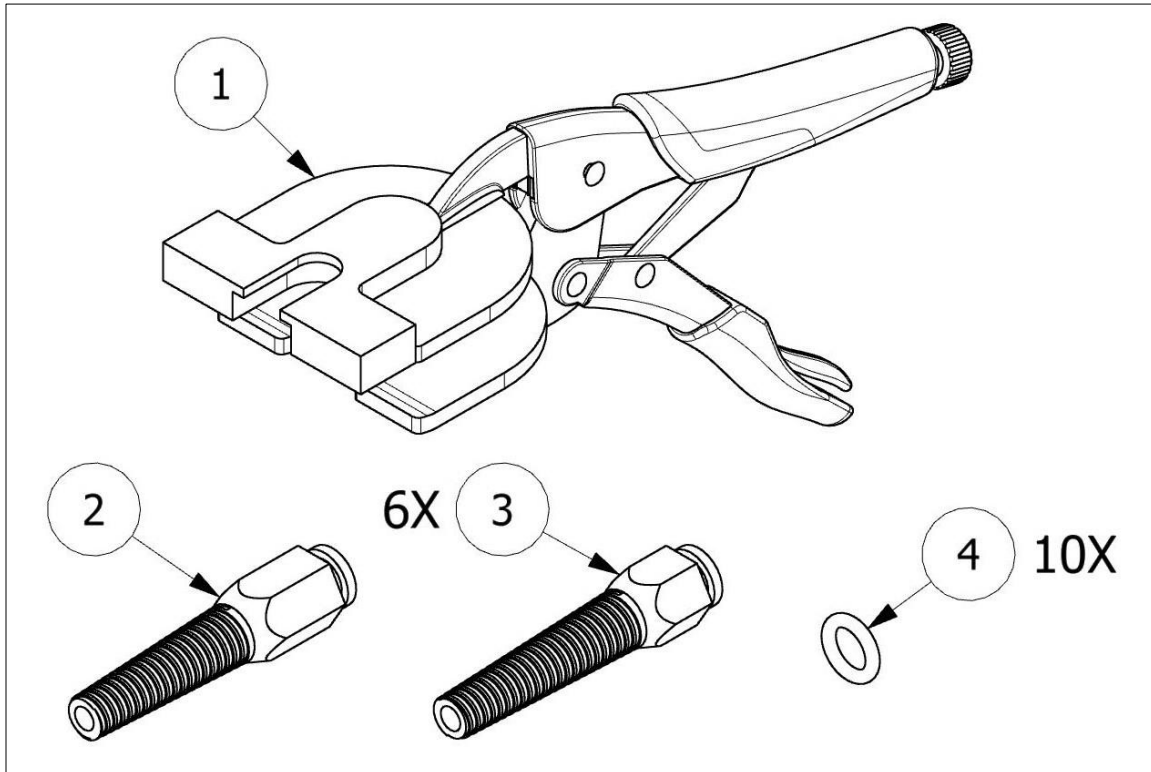

PX-7 Slab Jack Starter Kit

200720

ITEM	PART NUMBER	DESCRIPTION	QTY
1	200709	CLAMP, PX-7	1
2	200719	METAL PACKER W/ SLEEVE	1
3	200721	PLASTIC PACKER W/ SLEEVE – 6 PACK	1
4	OR-00037A	O-RING, -011, VITON	10

Plastic Packer w/ Sleeve – 6 Pack

Plastic Packer w/ Sleeve – 6 Pack

200721

PART NUMBER	DESCRIPTION	QTY
200726	CONCRETE POUR ADAPTER, PX-7	6

Starter Pack, 3/8 Bang-In Pack

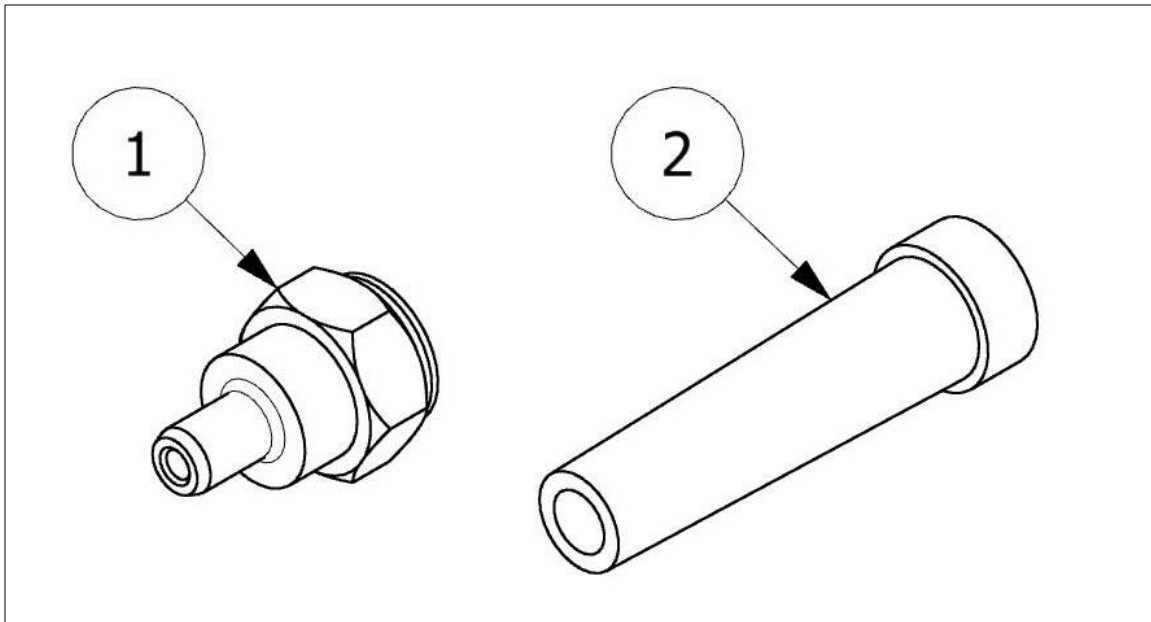

Starter Pack, 3/8 Bang-In Pack 202303

ITEM	PART NUMBER	DESCRIPTION	QTY
1	201544	CONCRETE POUR ADAPTER, PX-7	1
2	201545	PACKER, 3/8 OD	6