

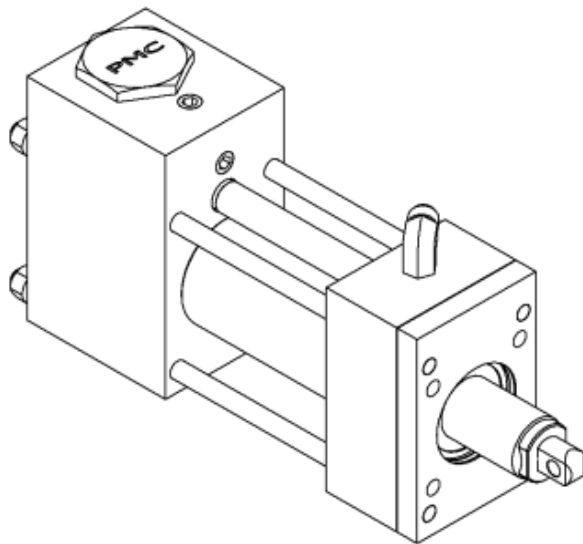

**POLYURETHANE
MACHINERY
CORPORATION**



Proportioning Pump Rebuild Kits

For Hydraulic, Heated, Plural Component
Proportioners

For Professional Use Only

Instructions



Subscribe to our channel,
**Polyurethane Machinery
Corporation PMC**, for video
instructions.

**REVISION 2.3
July 7, 2021**

Polyurethane Machinery Corp.

Corporate: 1 Komo Dr, Lakewood, NJ 08701

Manufacturing: 2 Komo Dr, Lakewood, NJ 08701

Phone: 732-415-4400

Fax: 732-364-4025

URL: <http://www.polymac-usa.com>



Before rebuilding your proportioning pumps, carefully read all the technical and safety documentation included in these instructions. Pay special attention to the information in order to know and understand the operation and the conditions of use of the proportioning pump. All of the information is aimed at improving user safety and avoiding possible breakdowns from the incorrect use of the proportioning pump.

TABLE OF CONTENTS

WARRANTY	1
SAFETY AND HANDLING	3
REPLACEMENT KITS	5
RECOMMENDED TOOLS.....	9
INSTRUCTIONS.....	11
PISTON ASSEMBLY	11
PUMP BASE ASSEMBLY.....	12
CYLINDER ASSEMBLY	13
PART IDENTIFICATION	19
“R” PUMP ASSEMBLY; ALL SIZES.....	19
“A” PUMP ASSEMBLY; SIZE 120.....	21
“A” PUMP ASSEMBLY; SIZE 80, 60, 40.....	22
PUMP BASE ASSEMBLY.....	24
PISTON ASSEMBLY	25
MANUAL REVISIONS.....	27

WARRANTY

Polyurethane Machinery Corporation (hereinafter “PMC”) provides this **LIMITED WARRANTY** (hereinafter “Warranty”) to the original purchaser (hereinafter “Customer”) covering this equipment and the original PMC manufactured accessories delivered with the equipment (hereinafter “Product”) against defects in material or workmanship of the Product (hereinafter “Defect” or “Defective”) for a period of one (1) year from the date of first purchase as shown on the original PMC invoice (hereinafter “Warranty Period”).

If during the Warranty Period under normal use, the Product is suspected by Customer to be Defective in material or workmanship, it is Customer’s responsibility to contact PMC and return the Product to PMC as directed by PMC, freight prepaid. If PMC determines that the Product is Defective and that such Defect is covered by this Warranty, PMC will credit Customer for the reasonable freight charges incurred by Customer in returning the Defective Product to PMC, and PMC (or its authorized agent) will, at PMC’s option, repair or replace the Product, subject to the following:

Original Invoice: The original invoice must be kept as proof of the date of first sale and the Product serial number. The Warranty does not cover any Product if the Original Invoice appears to have been modified or altered, or when the serial number on the Product appears to have been altered or defaced.

Product Maintenance: It is the Customer’s responsibility to maintain the Product properly. See your maintenance schedule and owner’s manual for details. The Warranty does not cover an improperly maintained Product.

Non-PMC Components and Accessories: Non-PMC manufactured components and accessories that are used in the operation of the Product are not covered by this Warranty. Such components and accessories shall be subject to the warranty offered to the Customer, if any, by the original manufacturer of such component or accessory.

Other Warranty Exclusions: The Warranty does not cover any Product that PMC determines has been damaged or fails to operate properly due to misuse, negligence, abuse, carelessness, neglect, or accident. By way of example only, this includes:

- Normal wear and tear.
- Improper or unauthorized installation, repair, alteration, adjustment or modification of the product.
- Use of heating devices, pumping equipment, dispensers, or other parts or accessories with the product that have not been approved or manufactured by PMC.
- Failure to follow the operating instructions and recommendations provided by PMC.
- Cosmetic damage.
- Fire, flood, “acts of God,” or other contingencies beyond the control of PMC.

THE WARRANTY DESCRIBED HEREIN IS THE EXCLUSIVE REMEDY FOR THE CUSTOMER AND IS IN LIEU OF ALL OTHER WARRANTIES, EXPRESS, IMPLIED, STATUTORY OR OTHERWISE, AND THE IMPLIED WARRANTIES OF MERCHANTABILITY AND FITNESS FOR A PARTICULAR PURPOSE AND ALL OTHER WARRANTIES ARE HEREBY DISCLAIMED. TO THE FULLEST EXTENT PERMITTED BY LAW, PMC SHALL NOT BE RESPONSIBLE, WHETHER BASED IN CONTRACT, TORT (INCLUDING, WITHOUT LIMITATION, NEGLIGENCE), WARRANTY OR ANY OTHER LEGAL OR EQUITABLE GROUNDS, FOR ANY CONSEQUENTIAL, INDIRECT, INCIDENTAL, LOST PROFITS, SPECIAL, PUNITIVE OR EXEMPLARY DAMAGES, WHETHER TO PERSON OR PROPERTY, ARISING FROM OR RELATING TO THE PRODUCT, EVEN IF PMC HAS BEEN ADVISED OF THE POSSIBILITY OF SUCH LOSSES OR DAMAGES.

Non-Warranty Service by PMC: If PMC determines that the suspected Defect of the Product is not covered by this Warranty, disposition of the Product will be made pursuant to the terms and conditions of PMC's written estimate on a time and materials basis.

Continuing Warranty for Products Repaired or Replaced under Warranty: Following the repair or replacement of a Product covered by this Warranty, such Product will continue to be subject to the original Warranty for the remainder of original Warranty Period or for three (3) months from the repair or replacement date, whichever is longer.

No Rights Implied: Nothing in the sale, lease or rental of any Product by PMC shall be construed to grant any right, interest or license in or under any patent, trademark, copyright, trade secret or other proprietary right or material owned by anyone; nor does PMC encourage the infringement of same.

Exclusive Warranty: This writing is the final, complete, and exclusive expression of the Warranty covering the Product. Any statements made by PMC, its employees or agents that differ from the terms of this Warranty shall have no effect. It is expressly understood that Customer's acceptance of this Warranty, by performance or otherwise, is upon and subject solely to the terms and conditions hereof, and any additional or different terms and conditions proposed or expressed by Customer or anyone, whether in writing or otherwise, are null and void unless specifically agreed to in writing by an Officer of PMC.

SAFETY AND HANDLING

This chapter contains important information on the safety, handling, and use of your proportioning pumps.



Before rebuilding the proportioning pumps, carefully read all the technical and safety documentation included in this manual. Pay special attention to the information to know and understand the operation and the conditions of use of the proportioning pumps. All of the information is aimed at enhancing User Safety and avoiding possible breakdowns derived from the incorrect use of the proportioning pumps.

WARNING! Presents information to alert of a situation that might cause serious injuries if the instructions are not followed.

CAUTION! Presents information that indicates how to avoid damage to the Proportioner or how to avoid a situation that could cause minor injuries.

NOTE! Is relevant information of a procedure being carried out.

Careful study of this manual will enable the operator to know the characteristics of the proportioning pumps and the operating procedures. By following the instructions and recommendations contained herein, you will reduce the potential risk of accidents in the installation, use or maintenance of the proportioning pumps; you will provide a better opportunity for incident-free operation for a longer time, greater output and the possibility of detecting and resolving problems quickly and simply.

Keep this Operations Manual for future consultation of useful information at all times. If you lose this manual, ask for a new copy from your PMC Distributor or go online and visit our web site at www.polymac-usa.com.

The proportioning pumps have been designed and built for the application of polyurea chemical systems, polyurethane foam chemical systems, and some two-component epoxy systems.

WARNING! The design and configuration of the proportioning pump does not allow its use in potentially explosive atmospheres, or the pressure and temperature limits described in the technical specifications of this manual to be exceeded.

Always use liquids and solvents that are compatible with the unit. If in doubt, consult your PMC Distributor.

When working with the proportioning pump, it is recommended that the operator wear suitable clothing and elements of personal protection, including, without limitation, gloves, protective goggles, safety footwear, and face masks. Use breathing equipment when working with the pumps in enclosed spaces or in areas with insufficient ventilation. The introduction and follow-up of safety measures must not be limited to those described in this manual. Before starting up the proportioner, a comprehensive analysis must be made of the risks derived from the products to be dispensed, the type of application, and the working environment.



To prevent possible injury caused by incorrect handling of the raw materials and solvents used in the process, carefully read the Material Safety Data Sheet (MSDS) provided by your supplier.

Deal with the waste caused according to current regulations.

To avoid damage caused by the impact of pressurized fluids, do not open any connection or perform maintenance work on components subject to pressure until the pressure has been completely eliminated.

Use suitable protection when operating, maintaining or being present in the area where the equipment is functioning. This includes, but is not limited to, the use of protective goggles, gloves, shoes and safety clothing and breathing equipment.

The equipment includes components that reach high temperatures and can cause burns. Hot parts of the equipment must not be handled or touched until they have cooled completely.

To prevent serious injury through crushing or amputation, do not work with the equipment without the safety guards installed on the moving parts. Make sure that all the safety guards are correctly reinstalled at the end of the repair or maintenance work of the equipment.

REPLACEMENT KITS

120 A PUMP REBUILD KIT (KT-07000)		
PART NUMBER	QTY	DESCRIPTION
PU-03000	1	Triple Lip Seal, 120 Pump
PU-03005	1	Shaft Bearing, 120, "A" Side
PU-01016A-012	1	Piston Seal; 120 Pump
PU-01013A	1	Cylinder Flange Gasket
PU-05029	1	Pin
PU-05041	1	Piston Bearing, 120
PU-03019	1	Bullet, 120
OR-00011A	2	O-Ring; 12x2mm ID
OR-00046A	2	O-Ring #133; Viton 90D Pump Cy
OR-00044A	1	O-Ring #024; Lube Cylinder
OR-00020A	2	#136 Viton Lube Cylinder O-Rin
TN-04199	2	SHCS, Bolt, 3/8-24 x 2.5
PU-05030	1	Snap Ring
PU-03021	1	A Side Seal Tool
OR-00045A	2	O-Ring #028 Viton 90D
OR-00051B	1	O-Ring #218 Alfas 80D
PU-01003-IG	1	Discharge Ball Seat Gasket
PU-01003-DG	1	Inlet Ball Seat Gasket
PU-05023-1	1	Gasket; Pump Retainer Nut
RA-00065A	1	Plug; Pump Cylinder

120 R PUMP REBUILD KIT (KT-07001)		
PART NUMBER	QTY	DESCRIPTION
PU-03000	1	Triple Lip Seal, 120 Pump
PU-01016A-012	1	Piston Seal; 120 Pump
PU-01013A	1	Cylinder Flange Gasket
PU-03010	1	Shaft Bearing, 120, "R" Side
PU-05041	1	Piston Bearing, 120
PU-05029	1	Pin
PU-03019	1	Bullet, 120
OR-00011A	2	O-Ring; 12x2mm ID
OR-00046A	2	O-Ring #133; Viton 90D Pump Cy
PU-05030	1	Snap Ring
TN-04199	2	SHCS, Bolt, 3/8-24 x 2.5
OR-00045A	2	O-Ring #028 Viton 90D
OR-00051B	1	O-Ring #218 Alfas 80D
PU-01003-IG	1	Discharge Ball Seat Gasket
PU-01003-DG	1	Inlet Ball Seat Gasket
PU-05023-1	1	Gasket; Pump Retainer Nut

80 A PUMP REBUILD KIT (KT-07002)		
PART NUMBER	QTY	DESCRIPTION
PU-03001	1	Triple Lip Seal, 80 Pump
PU-03006	1	Shaft Bearing, 80, "A" Side
PU-01016A-008	1	Piston Seal; 80 Pump
PU-01013A	1	Cylinder Flange Gasket
PU-05029-80	1	Pin
PU-05042	1	Piston Bearing, 80
PU-03020	1	Bullet, 80
PU-03016	1	Retaining Ring, 80, "A" Side
OR-00011A	2	O-Ring; 12x2mm ID
OR-00046A	2	O-Ring #133; Viton 90D Pump Cy
OR-00020A	2	#136 Viton Lube Cylinder O-Rin
OR-00044A	1	O-Ring #024; Lube Cylinder
TN-04199	2	SHCS, Bolt, 3/8-24 x 2.5
PU-05030-80	1	Snap Ring
PU-03021	1	A Side Seal Tool
OR-00045A	2	O-Ring #028 Viton 90D
OR-00051B	1	O-Ring #218 Alfas 80D
PU-01003-IG	1	Discharge Ball Seat Gasket
PU-01003-DG	1	Inlet Ball Seat Gasket
PU-05023-1	1	Gasket; Pump Retainer Nut
RA-00065A	1	Plug; Pump Cylinder
80 R PUMP REBUILD KIT (KT-07003)		
PART NUMBER	QTY	DESCRIPTION
PU-03001	1	Triple Lip Seal, 80 Pump
PU-03011	1	Shaft Bearing, 80, "R" Side
PU-01016A-008	1	Piston Seal; 80 Pump
PU-01013A	1	Cylinder Flange Gasket
PU-05029-80	1	Pin
PU-05042	1	Piston Bearing, 80
PU-03020	1	Bullet, 80
OR-00011A	2	O-Ring; 12x2mm ID
OR-00046A	2	O-Ring #133; Viton 90D Pump Cy
PU-05030-80	1	Snap Ring
TN-04199	2	SHCS, Bolt, 3/8-24 x 2.5
OR-00045A	2	O-Ring #028 Viton 90D
OR-00051B	1	O-Ring #218 Alfas 80D
PU-01003-IG	1	Discharge Ball Seat Gasket
PU-01003-DG	1	Inlet Ball Seat Gasket
PU-05023-1	1	Gasket; Pump Retainer Nut

60 A PUMP REBUILD KIT (KT-07004)		
PART NUMBER	QTY	DESCRIPTION
OR-00011A	2	O-Ring; 12x2mm ID
OR-00020A	2	#136 Viton Lube Cylinder O-Rin
OR-00044A	1	O-Ring #024; Lube Cylinder
OR-00046A	2	O-Ring #133; Viton 90D Pump Cy
PU-01013A	1	Cylinder Flange Gasket
OR-00051B	1	O-Ring; #218 Aflas 80D
PU-05029-60	1	Pin
PU-03002	1	Triple Lip Seal, 60 Pump
PU-03007	1	Shaft Bearing, 60, "A" Side
PU-03016	1	Retaining Ring, 80, "A" Side
PU-05043	1	Piston Bearing, 60
PU-03021	1	A Side Seal Tool
PU-03022	1	Bullet, 60
PU-01017A-006	1	Cylinder Seal; 60 Pump
TN-04199	2	SHCS, Bolt, 3/8-24 x 2.5
OR-00045A	2	O-Ring #028 Viton 90D
OR-00051B	1	O-Ring #218 Aflas 80D
PU-01003-IG	1	Discharge Ball Seat Gasket
PU-01003-DG	1	Inlet Ball Seat Gasket
PU-05023-1	1	Gasket; Pump Retainer Nut
RA-00065A	1	Plug; Pump Cylinder
60 R PUMP REBUILD KIT (KT-07005)		
PART NUMBER	QTY	DESCRIPTION
OR-00011A	2	O-Ring; 12x2mm ID
OR-00046A	2	O-Ring #133; Viton 90D Pump Cy
OR-00051B	1	O-Ring; #218 Aflas 80D
PU-01013A	1	Cylinder Flange Gasket
PU-05029-60	1	Pin
PU-03002	1	Triple Lip Seal, 60 Pump
PU-03012	1	Shaft Bearing, 60, "R" Side
PU-05043	1	Piston Bearing, 60
PU-01016A-006	1	Piston Seal; 60 Pump
TN-04199	2	SHCS, Bolt, 3/8-24 x 2.5
PU-03022	1	Bullet, 60
OR-00045A	2	O-Ring #028 Viton 90D
OR-00051B	1	O-Ring #218 Aflas 80D
PU-01003-IG	1	Discharge Ball Seat Gasket
PU-01003-DG	1	Inlet Ball Seat Gasket
PU-05023-1	1	Gasket; Pump Retainer Nut

40 A PUMP REBUILD KIT (KT-07006)		
PART NUMBER	QTY	DESCRIPTION
KT-01016A-004	1	Piston Seal; 40 Pump Kit
OR-00011A	2	O-Ring; 12x2mm ID
OR-00020A	2	#136 Viton Lube Cylinder O-Rin
OR-00046A	2	O-Ring #133; Viton 90D Pump Cy
OR-00051B	1	O-Ring; #218 Aflas 80D
PU-01013A	1	Cylinder Flange Gasket
PU-05029-40	1	Pin
PU-03003	1	Triple Lip Seal, 40 Pump
PU-03017	1	Retaing Ring, 40, 28, A Side
PU-03008	1	Shaft Bearing 40, "A" Side
PU-05044	1	Piston Bearing, 40
PU-03021	1	A Side Seal Tool
TN-04199	2	SHCS, Bolt, 3/8-24 x 2.5
PU-03023	1	Bullet, 40
OR-00045A	2	O-Ring #028 Viton 90D
OR-00051B	1	O-Ring #218 Alfas 80D
PU-01003-IG	1	Discharge Ball Seat Gasket
PU-01003-DG	1	Inlet Ball Seat Gasket
PU-05023-1	1	Gasket; Pump Retainer Nut
OR-00044A	1	O-Ring #024; Lube Cylinder
RA-00065A	1	Plug; Pump Cylinder
40 R PUMP REBUILD KIT (KT-07007)		
PART NUMBER	QTY	DESCRIPTION
KT-01016A-004	1	Piston Seal; 40 Pump Kit
OR-00011A	2	O-Ring; 12x2mm ID
OR-00046A	2	O-Ring #133; Viton 90D Pump Cy
OR-00051B	1	O-Ring; #218 Aflas 80D
PU-01013A	1	Cylinder Flange Gasket
PU-05029-40	1	Pin
PU-03013	1	Shaft Bearing, 40 " R" Side
PU-05044	1	Piston Bearing, 40
PU-03003	1	Triple Lip Seal, 40 Pump
PU-03023	1	Bullet, 40
TN-04199	2	SHCS, Bolt, 3/8-24 x 2.5
OR-00045A	2	O-Ring #028 Viton 90D
OR-00051B	1	O-Ring #218 Alfas 80D
PU-01003-IG	1	Discharge Ball Seat Gasket
PU-01003-DG	1	Inlet Ball Seat Gasket
PU-05023-1	1	Gasket; Pump Retainer Nut

RECOMMENDED TOOLS

RECOMMENDED TOOLS
120 Pump Line
9/16" Socket
Torque Wrench
1" Open Ended Wrench
5/16" Allen Wrench
Rubber Mallet

RECOMMENDED TOOLS
80 Pump Line
9/16" Socket
Torque Wrench
7/8" Open Ended Wrench
5/16" Allen Wrench
Rubber Mallet

RECOMMENDED TOOLS
60 Pump Line
9/16" Socket
Torque Wrench
13/16" Open Ended Wrench
5/16" Allen Wrench
Rubber Mallet

RECOMMENDED TOOLS
40 Pump Line
9/16" Socket
Torque Wrench
5/8" Open Ended Wrench
5/16" Allen Wrench
Rubber Mallet

NOTE! Both configurations are fully compatible with each other.

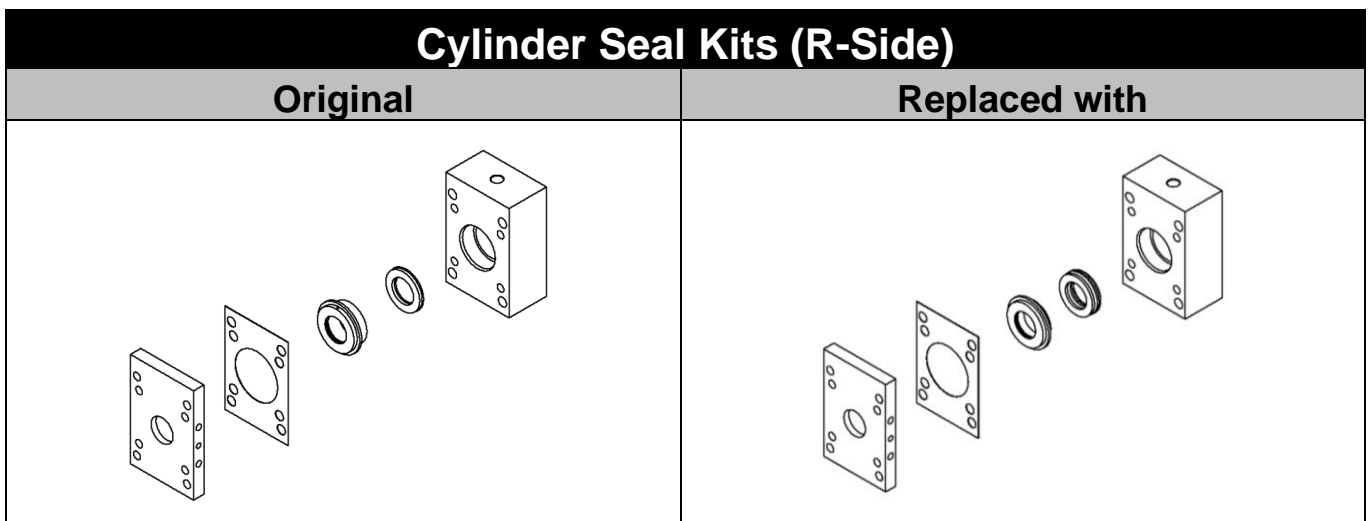
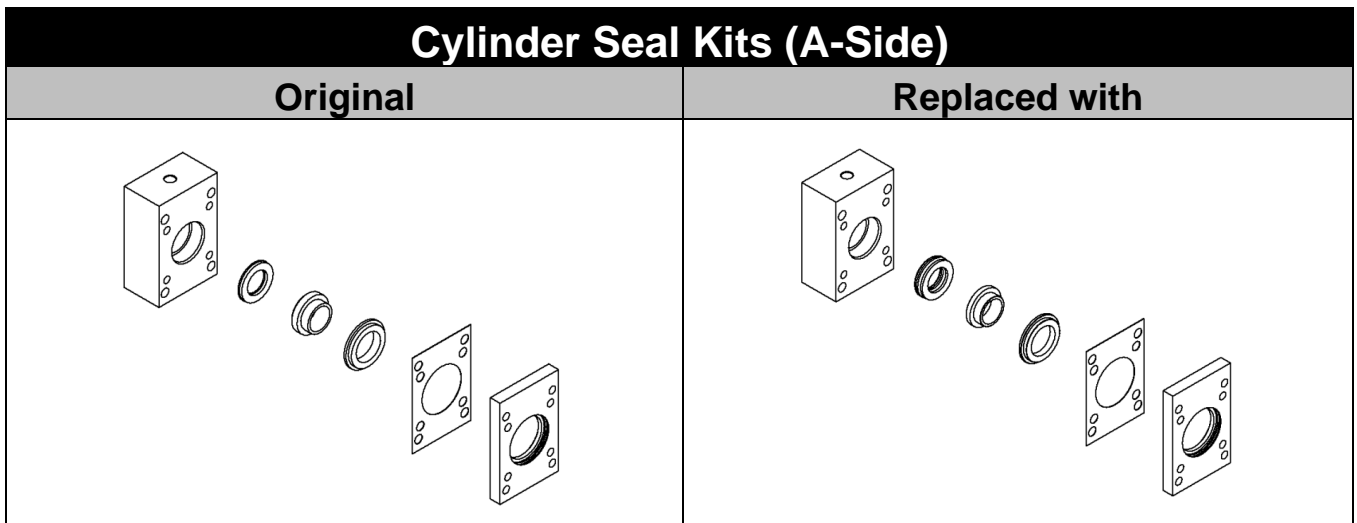
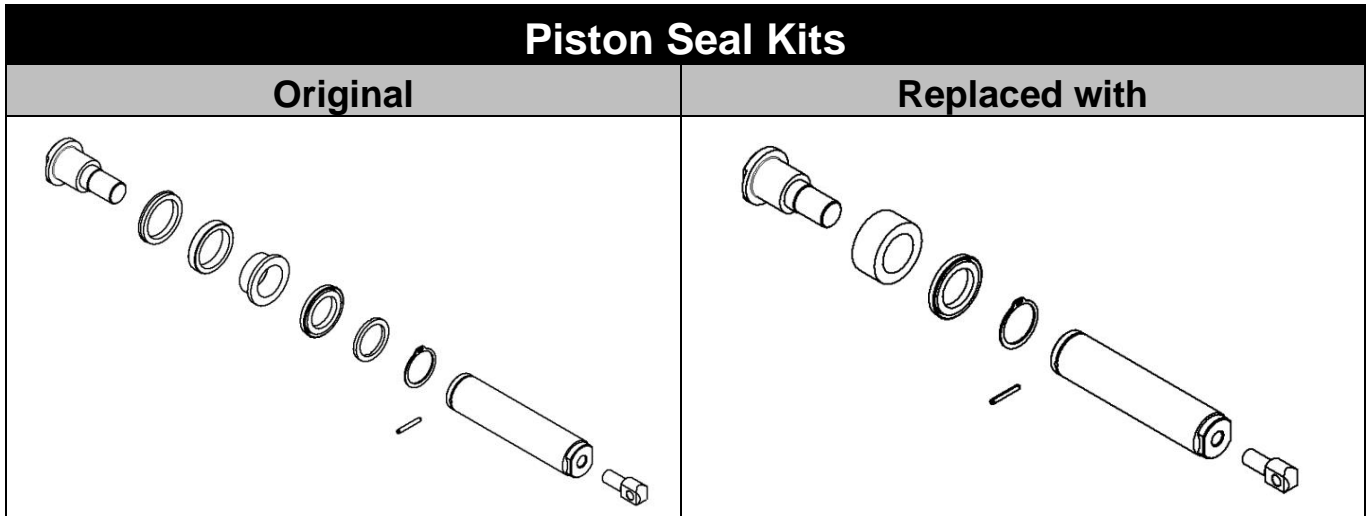

INSTRUCTIONS

CAUTION! When rebuilding any pump, it is highly recommended to replace **ALL** O-rings and seals, regardless of condition. When replacing O-rings and seals, always apply liberal amounts of PMC approved grease (GP-LUBEGREASE) to both the O-ring or seal, as well as all corresponding sealing surfaces.

PISTON ASSEMBLY

1. Install the **Piston Bearing** onto the **Piston Head**.
2. Install the **Piston Seal** onto the **Piston Head**, making sure the U-cup faces away from the **Piston Bearing** (as shown).
3. Insert the **Piston Head** into the **Piston Shaft** and tighten. The pin holes should align.
4. Insert the **Pin**
5. Install the **Snap Ring** into the **snap ring groove** on the **Piston Rod**, being careful not to damage the surface of the **Piston Rod**.

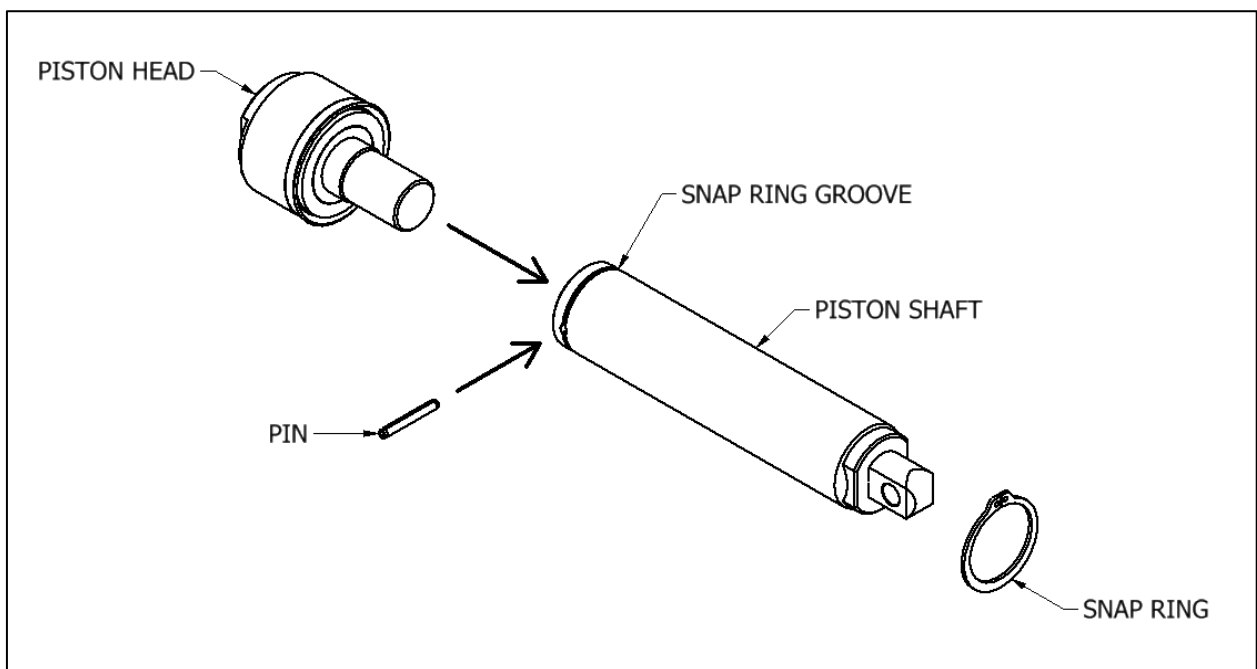
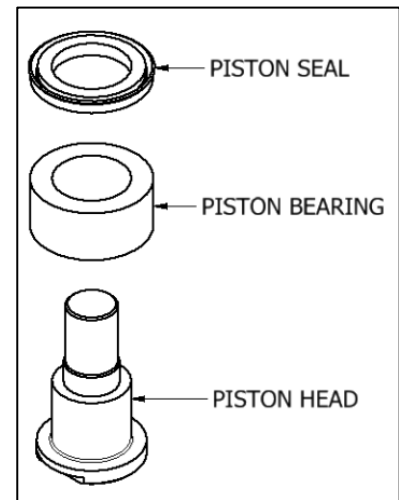
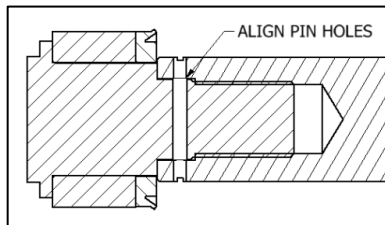

PUMP BASE ASSEMBLY

CLOSE appropriate (A or R) pump inlet material supply valve and remove air line from transfer pump. Ensure all material pressure in the Proportioner system is zero (0). **PUMP BASE REBUILD KIT PART NUMBER IS 202355. KIT 202305 IS ALSO NEEDED IF CUSTOMER HAS OLD STYLE SLEEVE/NUT.**

1. Remove appropriate **Pump Retainer Nut** (11).
2. Remove the **Discharge Ball** (10) with a Magnet then remove the sleeve using tool number 200706, remove the **Spring** (5) from the **Pump Base** (1).
3. Using the magnet remove the 1" **Inlet Ball** (4) from the **Pump Base** (1).
4. Remove the **Inlet Seat** (3) using tool number TL-02 then remove the **Gasket** (2).
5. Install the new **Gasket** (2) and **Ball Seat** (3). With the TL-02 tool snug the **Seat** (3) up to ¼ turn max. 110 ft-lbs. (149 N-m).
6. Remove the **O-Ring** (7) and insert the **Sleeve** (6) into a vice (use wood inside the jaws not to damage the **Sleeve**).
7. Remove the **Discharge Seat** (9) using tool number TL-02 then remove the **Gasket** (8).
8. Install the new **Gasket** (8) then install the **Seat** (9) using tool number TL-02. Snug the **Seat** (9) up to ¼ turn maximum 30 ft-lbs. (41 N-m).
9. Install the **O-Ring** (7) onto the **Sleeve** (6) and lube the outside of the **O-Ring** (7).
10. Drop in the 1" **Inlet Ball** (4) then the **Spring** (5).
11. Using the TL-02 tool or palm of your hand, install the **Sleeve** (6) and push down with a turning motion in order to avoid damage to the O-ring during installation.
12. Replace the **Gasket** (12) on the **Pump Retainer Nut** (11) and screw it back in to the **Pump Base** (1).

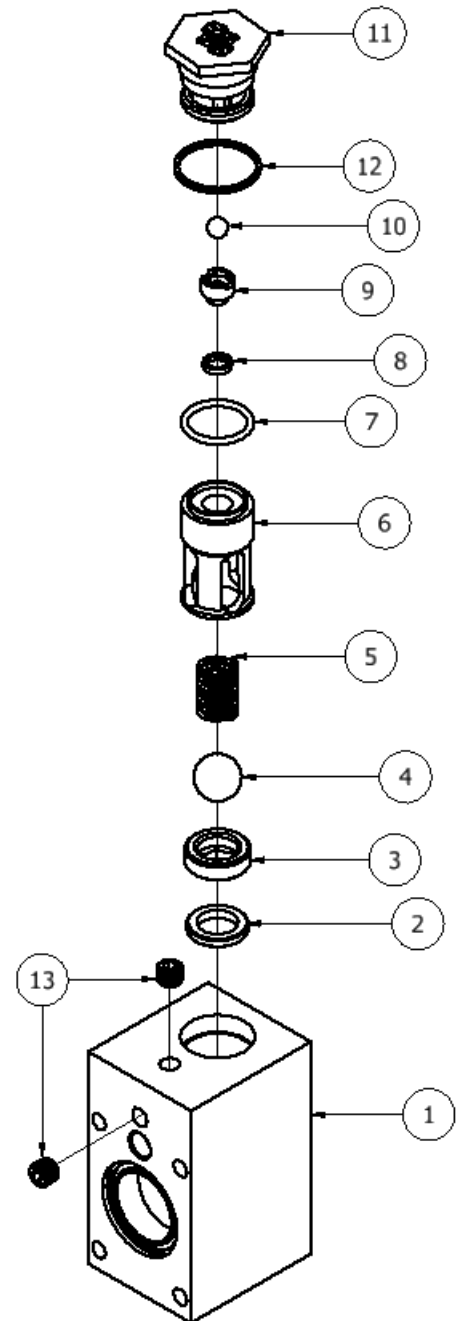

CYLINDER ASSEMBLY

1. Lay the **Packing Retainer** on a flat surface.

a. For "A" Side Pumps, lay the "**A**" Side **Packing Retainer** down (the side with the O-Ring groove is face down). Insert the "**A**" Side **Seal Tool** into the "**A**" Side **Packing Retainer**.

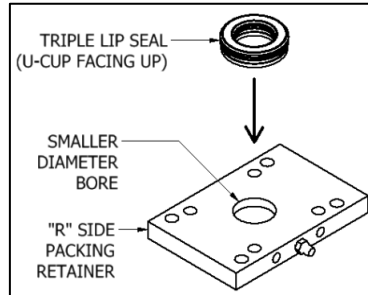

b. For "R" Side Pumps, lay the "**R**" Side **Packing Retainer** down (the side with the **smaller diameter bore** should be facing up)

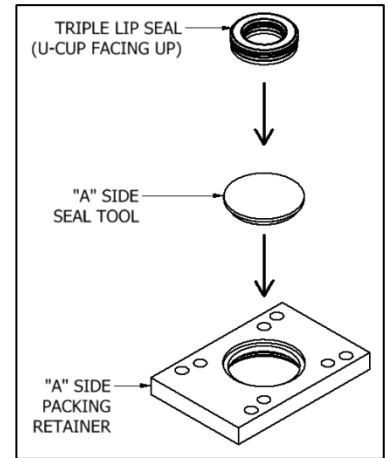

2. Lubricate (using PMC approved grease) the **Triple Lip Seal** and place it on top of the **Packing Retainer**, roughly centering it about the bore or seal tool.

3. Lubricate (using PMC approved grease) the bore of the **Pump Flange**, and carefully place the **Pump Flange** on top of the **Triple Lip Seal**, ensuring the **Triple Lip Seal** is centered in the bore of the **Pump Flange**.

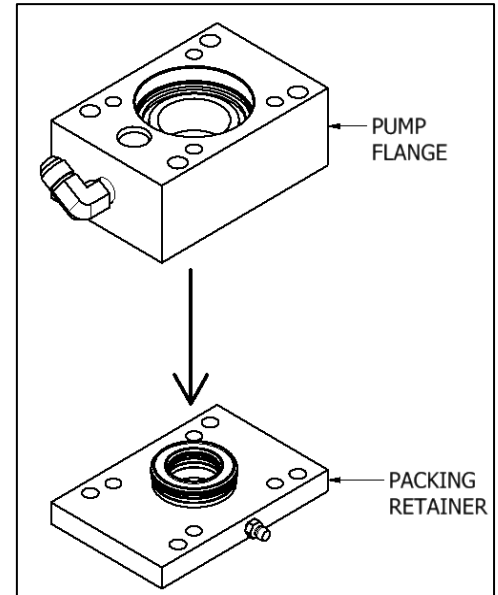

4. Insert the **Socket Head Cap Screws** as shown and tighten until **HAND TIGHT**.

5. Using an Allen Wrench, tighten the **Socket Head Cap Screws** using the following procedure:

- a. Tighten one of the screws 1-2 complete turns
- b. Tighten the other screw 1-2 complete turns
- c. Repeat until both screws are fully tightened

CAUTION! By alternating screws every 1-2 turns, the risk of damage to the seal due to improper installation is greatly reduced.

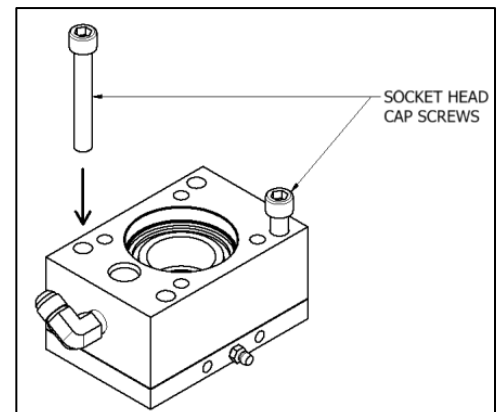

6. Place the **Pump Flange** on a flat surface with the **Triple Lip Seal** facing up.
 - a. When rebuilding R-Side Pumps (all sizes) and A-Side Pumps (size 120 ONLY), place the **Shaft Bearing** onto the **Triple Lip Seal**. The side of the **Shaft Bearing** with the smaller outside diameter should be facing the **Triple Lip Seal**.
 - b. When rebuilding A-Side Pumps (size 80 or below), place the **Retaining Ring** on the **Triple Lip Seal** with the larger diameter facing down. Then slide the **Shaft Bearing** over the **Retaining Ring** with the smaller diameter facing up. See the diagram for proper orientation.

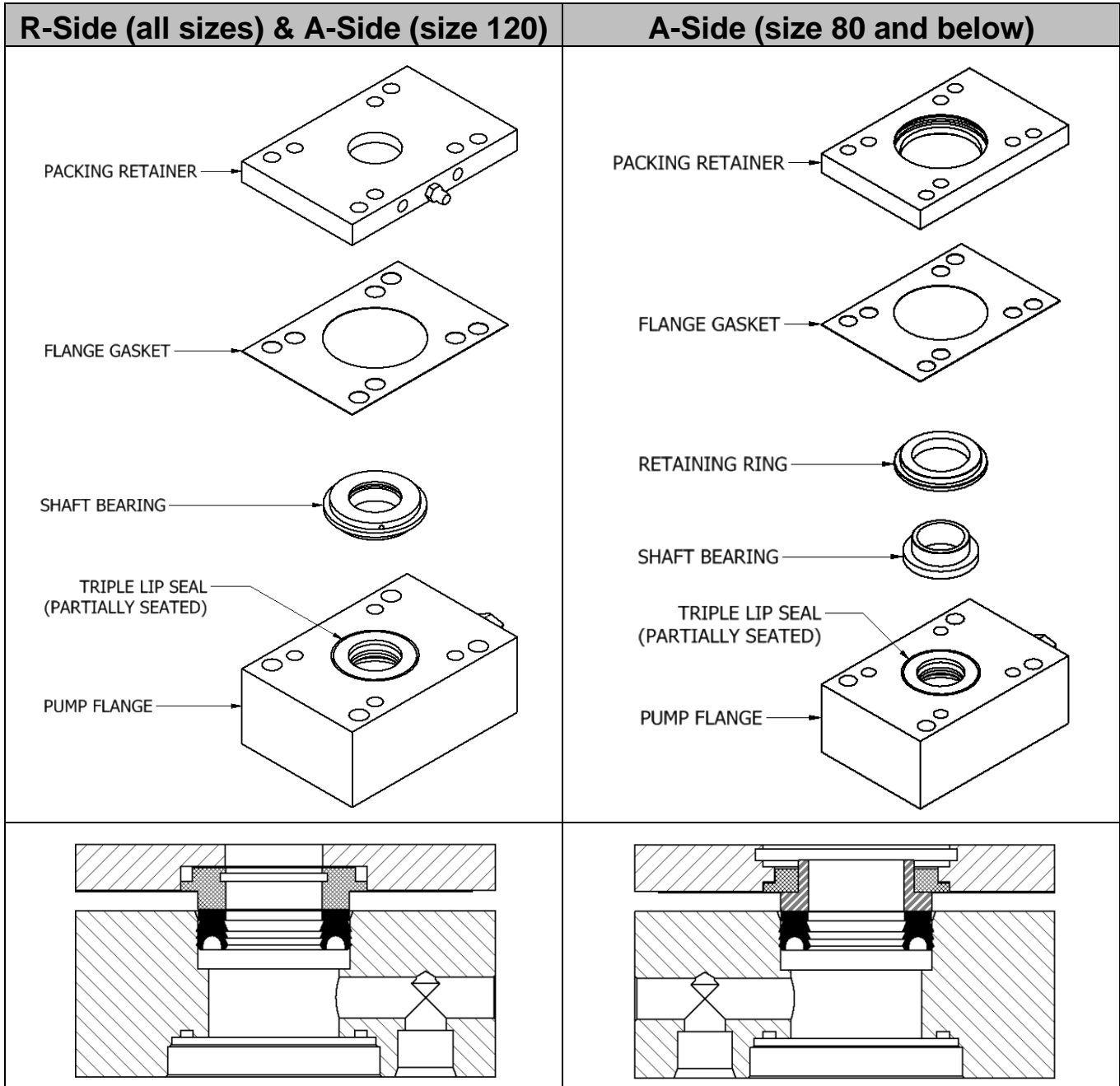

7. Lubricate (using PMC approved grease) the **O-Ring** and the groove in the **Pump Flange**, and install the **O-Ring** into the groove in the **Pump Flange**.
8. Install the **Tie Bolts** until they are flush with the **Packing Retainer**.

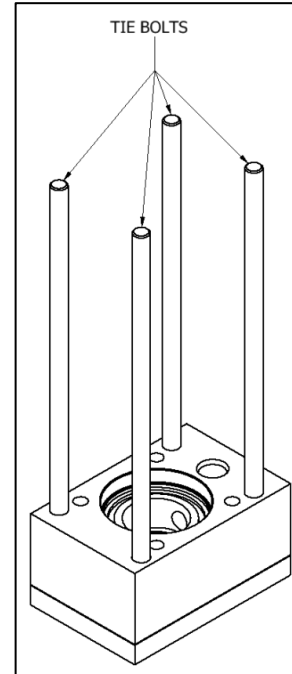
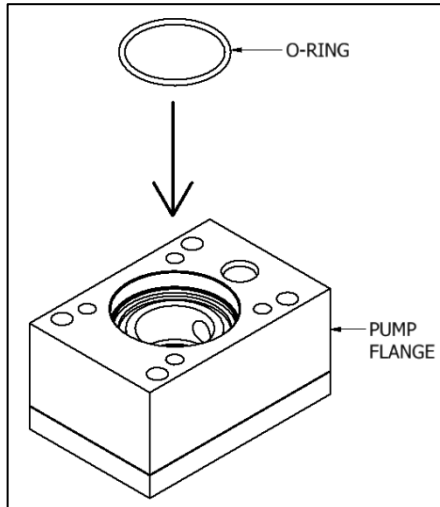

9. Place the **Pump Base** on a flat surface with the cylinder bore facing up (as shown below).
10. Lubricate (using PMC approved grease) the **O-Rings** and grooves on the **Crossover Tube**, and install the **O-Rings** into the grooves on the **Crossover Tube**.
11. Install the **Crossover Tube** into the **Pump Base**.
12. Lubricate (using PMC approved grease) the **O-Ring** and the groove in the **Pump Base**, and install the **O-Ring** into the groove in the **Pump Base**.
13. Lubricate (using PMC approved grease) the inside surface and both ends of the **Cylinder** and install it into the **Pump Base**.

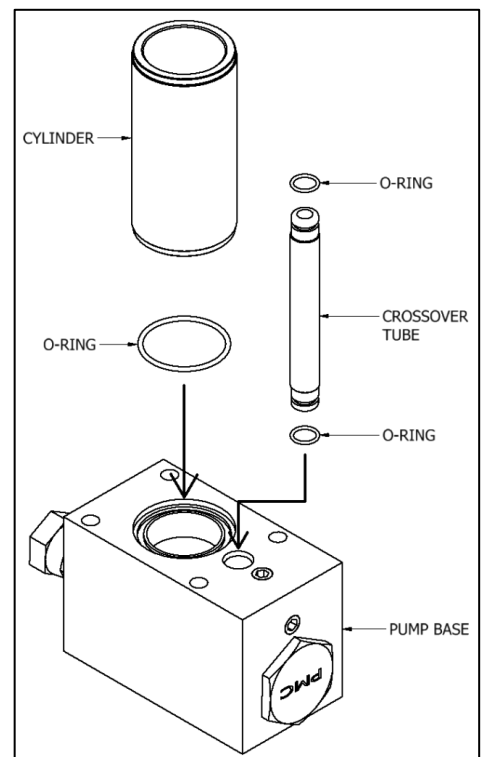

14. Install the **Piston** into the **Cylinder**. Push the **Piston** in until it bottoms out.
15. Install the **Bullet** onto the **Piston** and lubricate the outside of the **Bullet** (using PMC approved grease).

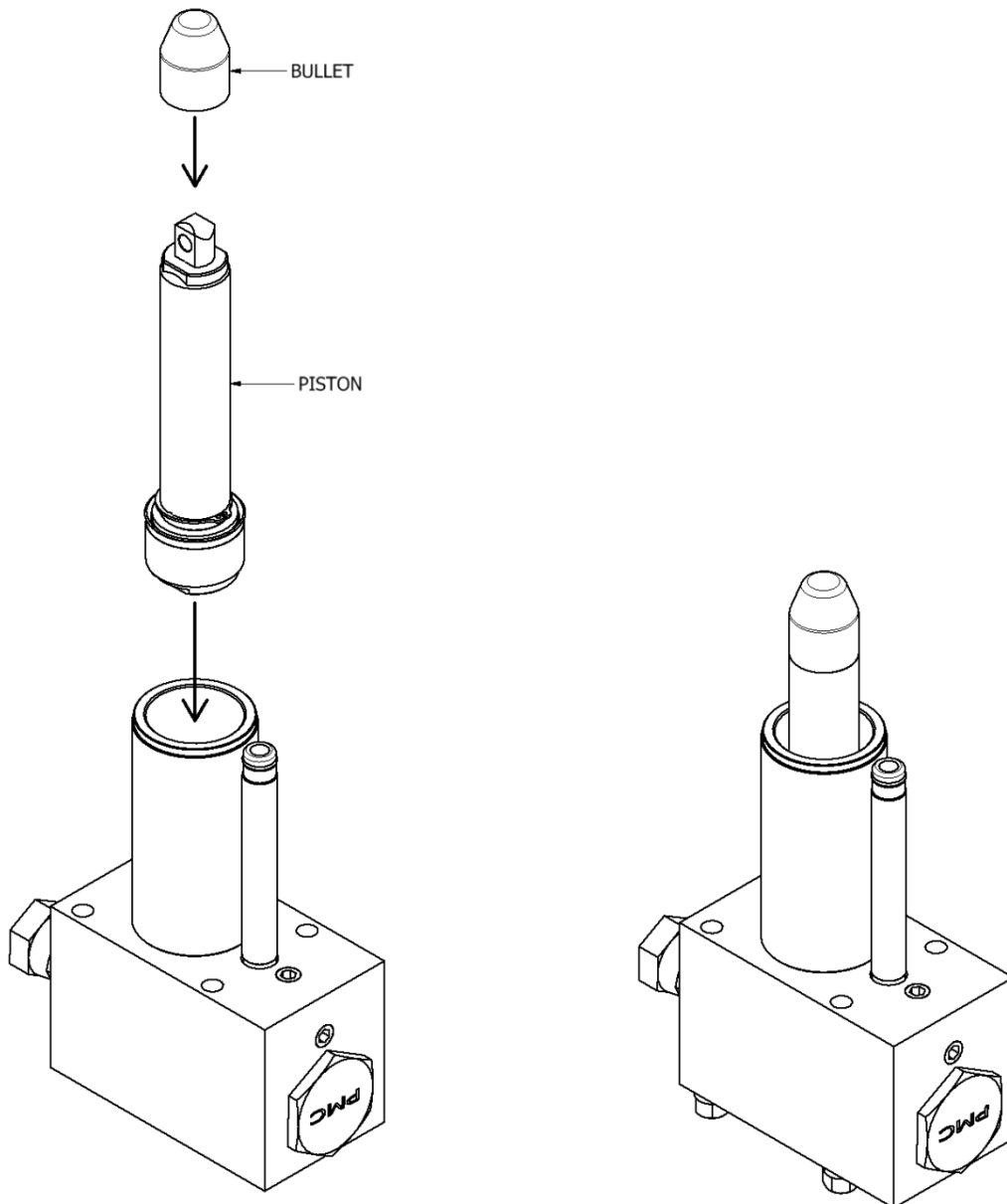

16. Ensure all sealing surfaces are lubricated (using PMC approved grease) and install the **Pump Flange** onto the **Pump Base Assembly** by lifting the **Pump Flange** over the **Pump Base Assembly** and simultaneously:

- a. Aligning and inserting the **Tie Rods** into the **Tie Rod Thru Holes**.
- b. Ensuring the **Piston Bullet** smoothly and evenly slides into the **Triple Lip Seal** (not shown) in the **Pump Flange** and exits through the other side of the **Pump Flange**.
- c. Aligning the **Crossover Tube** with the corresponding bore in the **Pump Flange**.

17. Lay the partially assembled **Pump** on its side, against a small ledge (as shown below). Ensure the ledge is small enough for the **Piston** to freely exit the **Pump Flange**.

18. Use a **Mallet** to **GENTLY TAP** the **Pump Base**. The **Tie Rods** should protrude from the **Pump Base**.

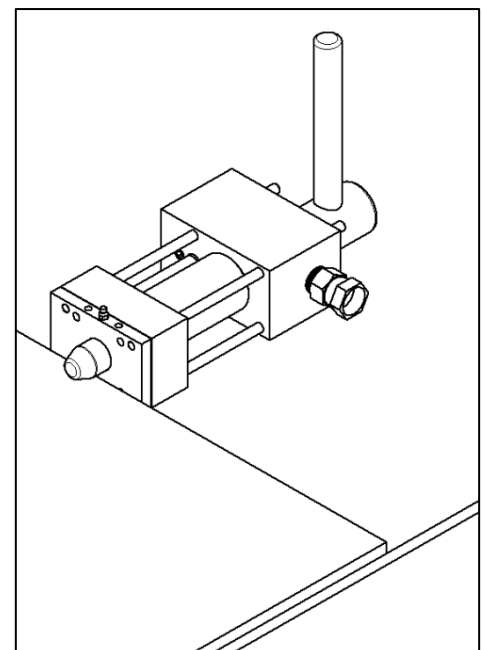
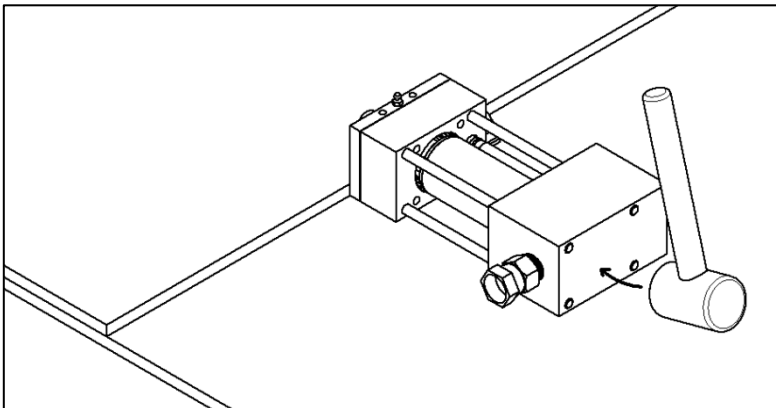
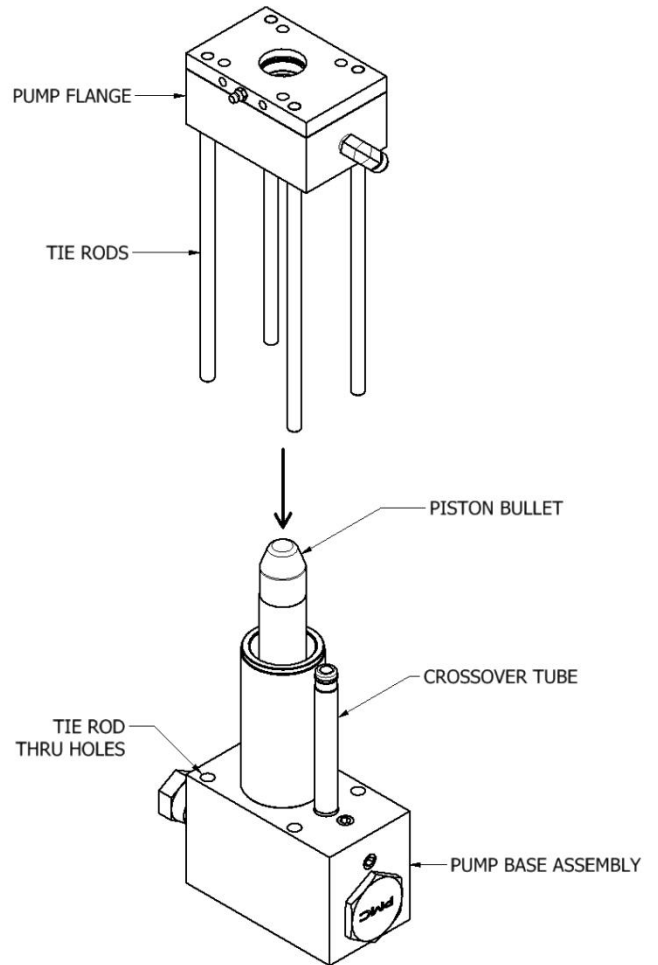

19. Remove the **Bullet**.

20. Add a **Washer** and **Nut** to each **Tie Rod** and tighten until **HAND TIGHT**.

21. Using a 9/16" socket and torque wrench, torque each **Nut** to 30 ft-lbs (41 N-m) in an X-pattern as shown.

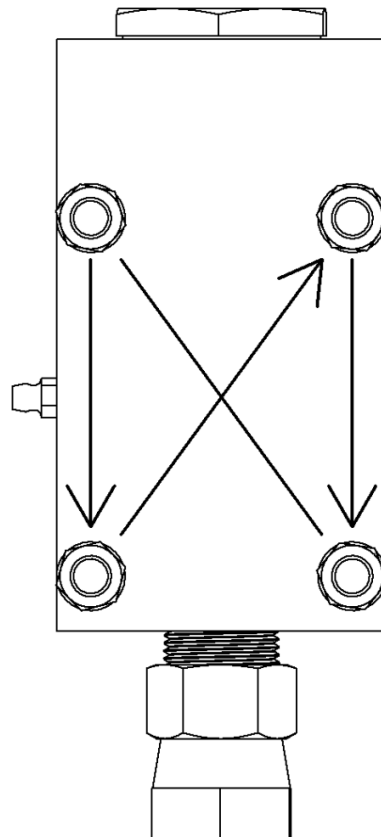
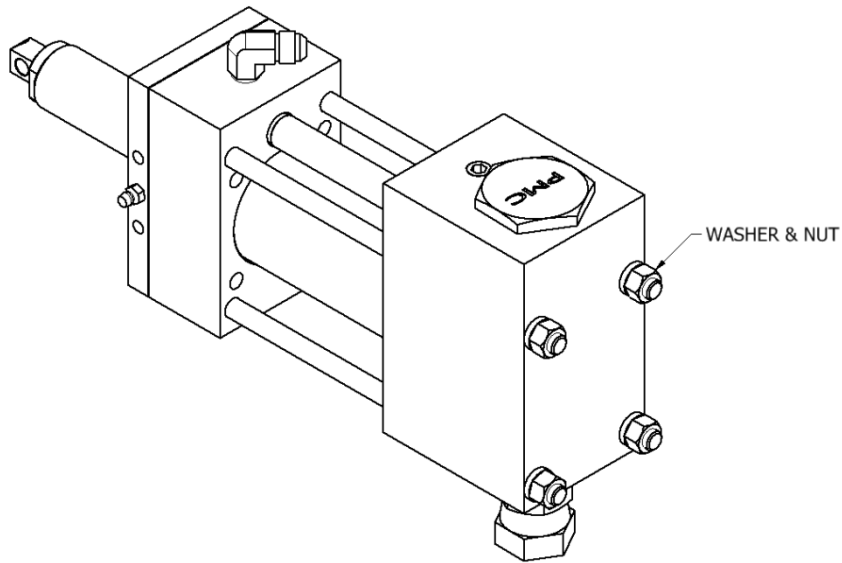

PART IDENTIFICATION

“R” PUMP ASSEMBLY; ALL SIZES

(PU-05002-120)

(PU-05002-80)

(PU-05002-60)

(PU-05002-40)

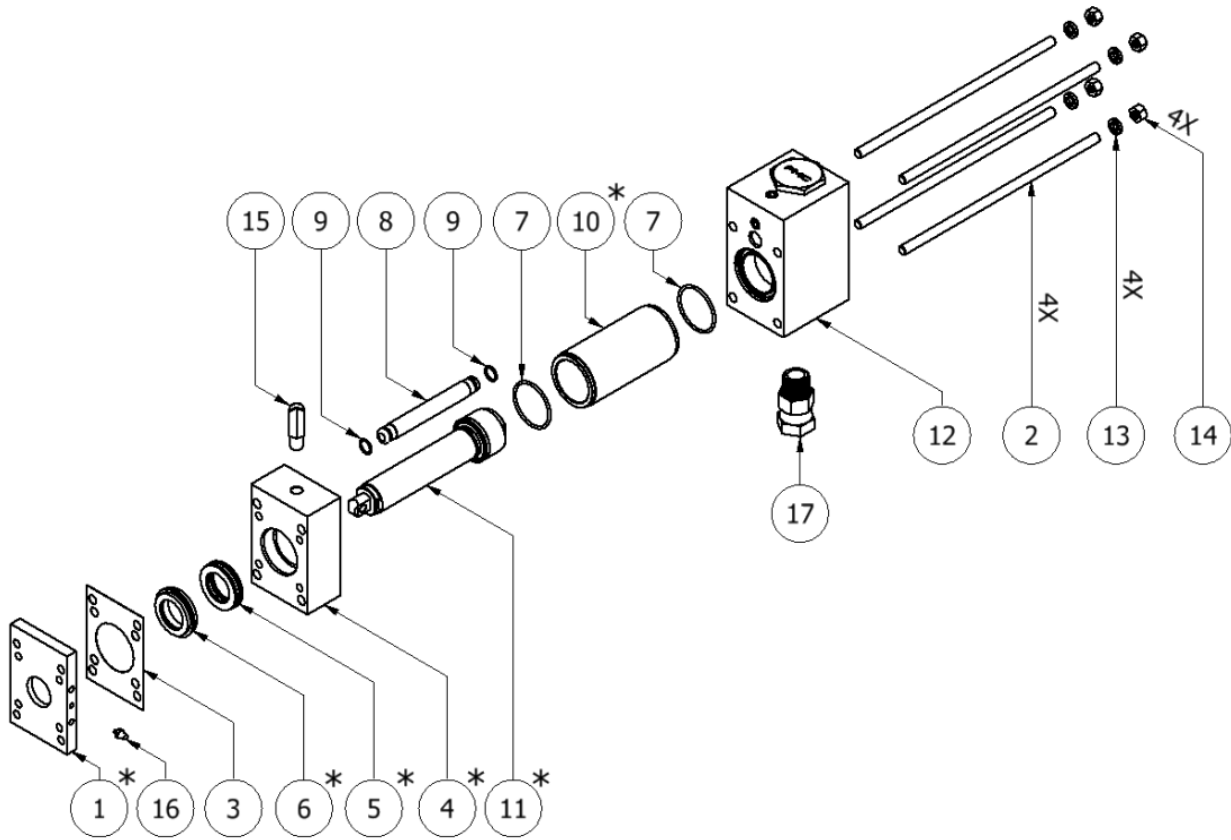

"R" PUMP ASSEMBLY PU-05002-120 PU-05002-80 PU-05002-60 PU-05002-40				
ITEM	QTY	PART NUMBER	DESCRIPTION	FOR PUMP
1*	1	PU-05032	"R" PACKING RETAINER FLANGE; SIZE 120	PU-05002-120
	1	PU-05032-80	"R" PACKING RETAINER FLANGE; SIZE 80	PU-05002-80
	1	PU-05032-60	"R" PACKING RETAINER FLANGE; SIZE 60	PU-05002-60
	1	PU-05032-40	"R" PACKING RETAINER FLANGE; SIZE 40	PU-05002-40
2	4	PU-05026	TIE ROD; 3/8-24	ALL PUMPS
3	1	PU-01013A	CYLINDER FLANGE GASKET	ALL PUMPS
4*	1	PU-05014	PUMP FLANGE; SIZE 120	PU-05002-120
	1	PU-05014-80	PUMP FLANGE; SIZE 80	PU-05002-80
	1	PU-05014-60	PUMP FLANGE; SIZE 60	PU-05002-60
	1	PU-05014-40	PUMP FLANGE; SIZE 40	PU-05002-40
5*	1	PU-03000	TRIPLE LIP SEAL, 120	PU-05002-120
	1	PU-03001	TRIPLE LIP SEAL, 80	PU-05002-80
	1	PU-03002	TRIPLE LIP SEAL, 60	PU-05002-60
	1	PU-03003	TRIPLE LIP SEAL, 40	PU-05002-40
6*	1	PU-03010	SHAFT BEARING, 120, R	PU-05002-120
	1	PU-03011	SHAFT BEARING, 80, R	PU-05002-80
	1	PU-03012	SHAFT BEARING, 60, R	PU-05002-60
	1	PU-03013	SHAFT BEARING, 40, R	PU-05002-40
7	2	OR-00046A	O-RING #133; VITON 90D PUMP CYL	ALL PUMPS
8	1	PU-05017	CROSSOVER TUBE	ALL PUMPS
9	2	OR-00011A	O-RING; CROSSOVER TUBE #014	ALL PUMPS
10*	1	PU-05012	CYLINDER; SIZE 120	PU-05002-120
	1	PU-05012-80	CYLINDER; SIZE 80	PU-05002-80
	1	PU-05012-60	CYLINDER; SIZE 60	PU-05002-60
	1	PU-05012-40	CYLINDER; SIZE 40	PU-05002-40
11*	1	SEE PAGE 24	PISTON ASSEMBLY	-
12	1	SEE PROPORTIONER MANUAL	PUMP BASE ASSEMBLY	-
13	4	PU-05027	WASHER	ALL PUMPS
14	4	PU-05028	NUT	ALL PUMPS
15	1	HI-05038	1/4 NPT X 9/16-18 JIC 90 DEG E	ALL PUMPS
16	1	TN-04186	GREASE FITTING	ALL PUMPS
17	1	HI-05016	3/4 MPT x 3/4 FPT SW	ALL PUMPS

*Indicates different parts for different pump sizes.

"A" PUMP ASSEMBLY; SIZE 120

(PU-05001-120)

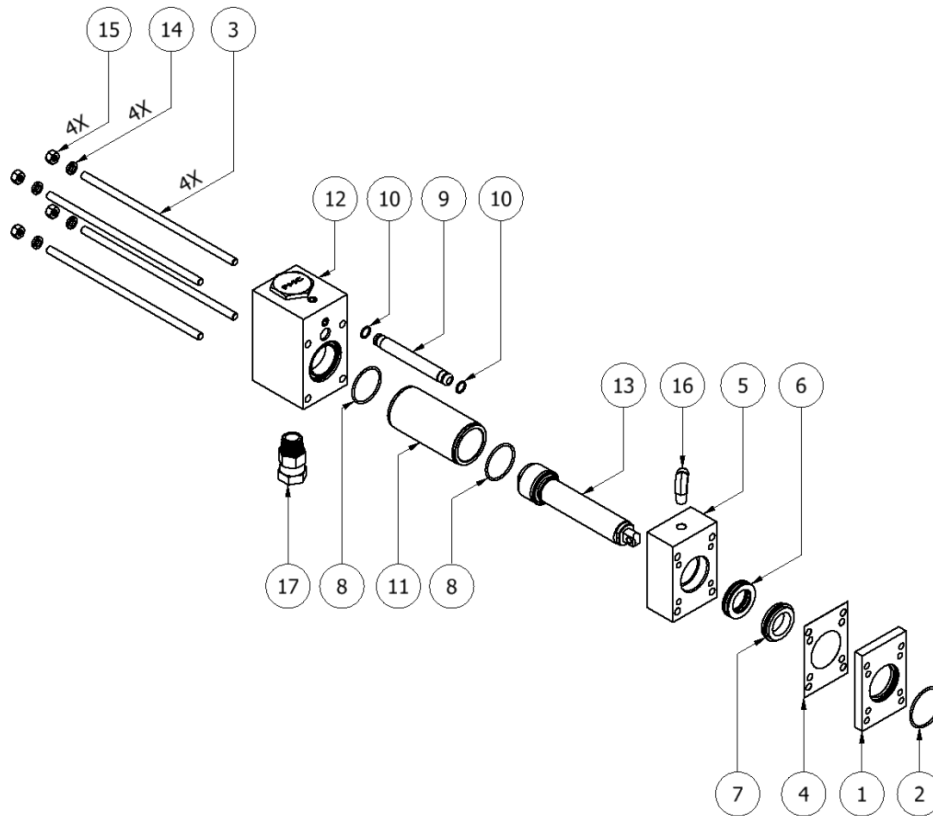

"A" PUMP ASSEMBLY, 120 PU-05001-120			
ITEM	QTY	PART NUMBER	DESCRIPTION
1	1	PU-05013	"A" PACKING RETAINER FLANGE
2	1	OR-00020A	#136 VITON LUBE CYLINDER O-RING
3	4	PU-05026	TIE ROD; 3/8-24
4	1	PU-01013A	CYLINDER FLANGE GASKET
5	1	PU-05014	PUMP FLANGE
6	1	PU-03000	TRIPLE LIP SEAL, 120
7	1	PU-03005	SHAFT BEARING, 120, A
8	2	OR-00046A	O-RING #133; VITON 90D PUMP CYL
9	1	PU-05017	CROSSOVER TUBE
10	2	OR-00011A	O-RING; CROSSOVER TUBE #014
11	1	PU-05012	CYLINDER
12	1	SEE PROPORTIONER MANUAL	PUMP BASE ASSEMBLY
13	1	SEE PAGE 24	PISTON ASSEMBLY
14	4	PU-05027	WASHER
15	4	PU-05028	NUT
16	1	HI-05038	1/4 NPT X 9/16-18 JIC 90 DEG E
17	1	HI-05016	3/4 MPT X 3/4 FPT SW

"A" PUMP ASSEMBLY; SIZE 80, 60, 40

(PU-05001-80)

(PU-05001-60)

(PU-05001-40)

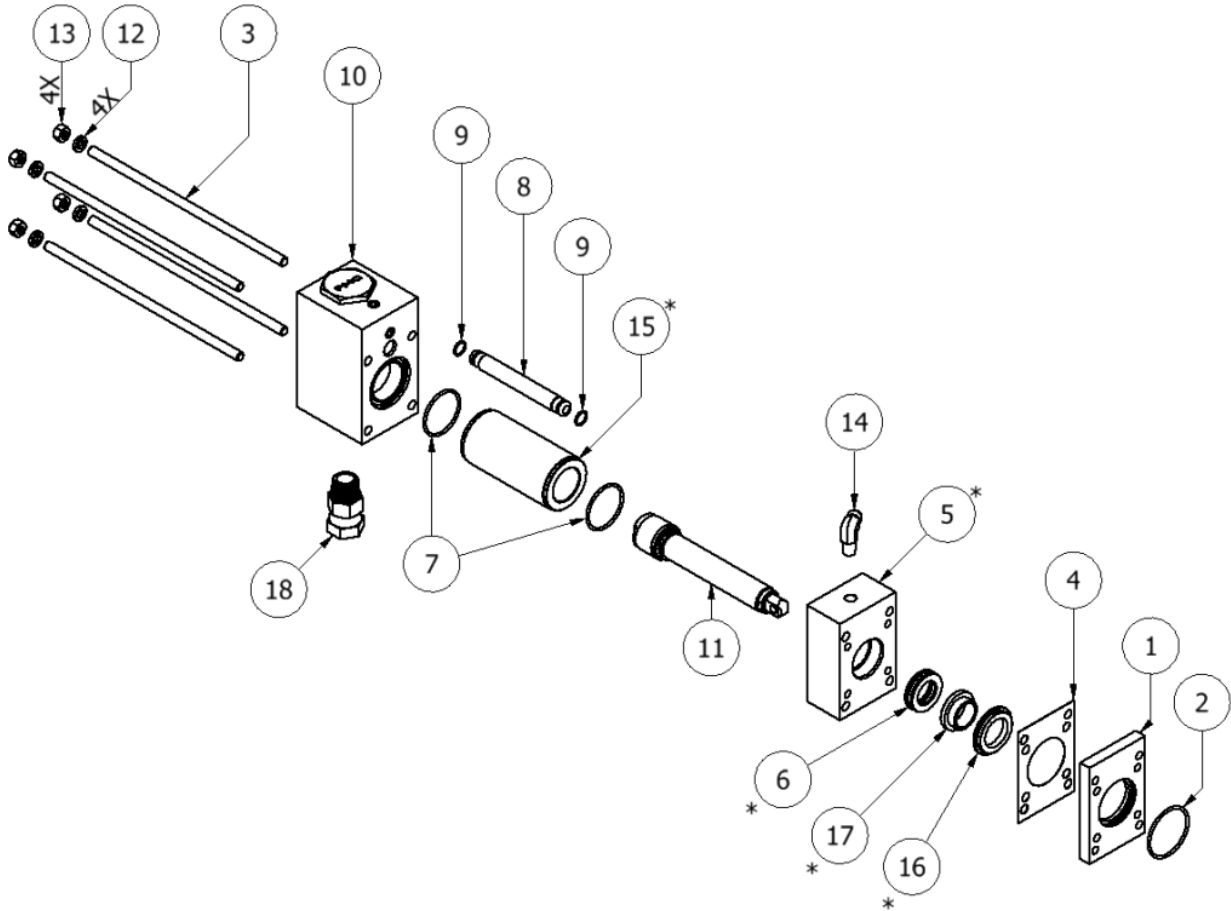

"A" PUMP ASSEMBLY, SIZE 80, 60, 40 PU-05001-80 PU-05001-60 PU-05001-40				
ITEM	QTY	PART NUMBER	DESCRIPTION	FOR PUMP
1	1	PU-05013	"A" PACKING RETAINER FLANGE	ALL
2	1	OR-00020A	#136 VITON LUBE CYLINDER O-RING	ALL
3	4	PU-05026	TIE ROD; 3/8-24	ALL
4	1	PU-01013A	CYLINDER FLANGE GASKET	ALL
5*	1	PU-05014-80	PUMP FLANGE, 80	PU-05001-80
	1	PU-05014-60	PUMP FLANGE, 60	PU-05001-60
	1	PU-05014-40	PUMP FLANGE, 40	PU-05001-40
6*	1	PU-03001	TRIPLE LIP SEAL, 80	PU-05001-80
	1	PU-03002	TRIPLE LIP SEAL, 60	PU-05001-60
	1	PU-03003	TRIPLE LIP SEAL, 40	PU-05001-40
7	2	OR-00046A	O-RING #133; VITON 90D PUMP CYL	ALL
8	1	PU-05017	CROSSOVER TUBE	ALL
9	2	OR-00011A	O-RING; CROSSOVER TUBE #014	ALL
10	1	SEE PROPORTIONER MANUAL	PUMP BASE ASSEMBLY	-
11	1	SEE PAGE 24	PISTON ASSEMBLY	-
12	4	PU-05027	WASHER	ALL
13	4	PU-05028	NUT	ALL
14	1	HI-05038	1/4 NPT X 9/16-18 JIC 90 DEG E	ALL
15*	1	PU-05012-80	CYLINDER, 80	PU-05001-80
	1	PU-05012-60	CYLINDER, 60	PU-05001-60
	1	PU-05012-40	CYLINDER, 40	PU-05001-40
16*	1	PU-03016	RETAINING RING, 80, 60, A	PU-05001-80 PU-05001-60
	1	PU-03017	RETAINING RING, 40, 28, A	PU-05001-40
17*	1	PU-03006	SHAFT BEARING, 80, A	PU-05001-80
	1	PU-03007	SHAFT BEARING, 60, A	PU-05001-60
	1	PU-03008	SHAFT BEARING, 40, A	PU-05001-40
18	1	HI-05016	3/4 MPT X 3/4 FPT SW	ALL

*Indicates different parts for different pump sizes.

PUMP BASE ASSEMBLY

PUMPBASE ASSEMBLY			
ITEM	QTY	PART NUMBER	DESCRIPTION
1	1	PU-05018	PUMP BASE
2	1	PU-01003-DG	INLET BALL SEAT GASKET
3	1	PU-05019	INLET SEAT
4	1	PU-05020	INLET BALL
5	1	PU-05021	SPRING
6	1	PU-05022A	SLEEVE
7	1	OR-00051B	#218 AFLAS 80D O-RING
8	1	PU-01003-IG	DISCHARGE BALL SEAT GASKET
9	1	PU-05024	DISCHARGE SEAT
10	1	PU-05025	DISCHARGE BALL
11	1	PU-05023-R	PUMP RETAINER NUT
12	1	PU-05023-1	GASKET
13	2	HI-05067	PIPE PLUG 1/4-18; 7/8 TAPER

***PUMP BASE REBUILD KIT PART NUMBER IS 202355**

***KIT 202305 IS ALSO NEEDED IF CUSTOMER HAS OLD STYLE SLEEVE/NUT (DEPICTED BELOW)**

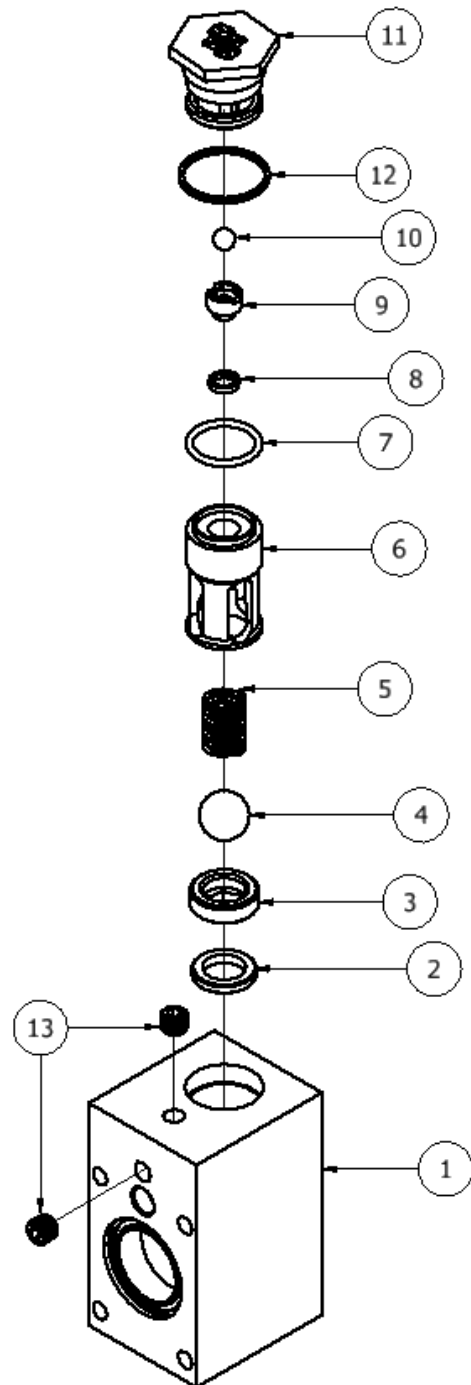
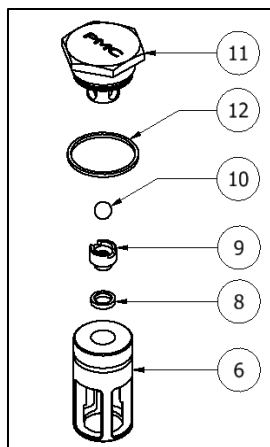

PISTON ASSEMBLY

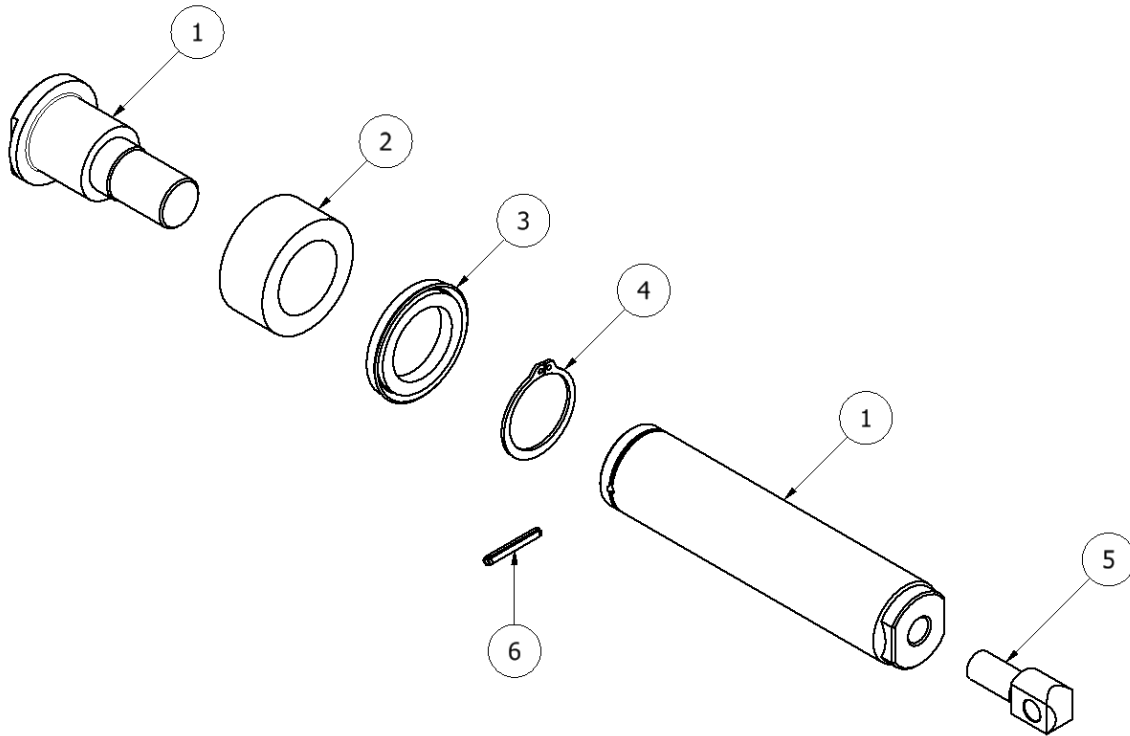

120 PUMP PISTON ASSEMBLY			
ITEM	QTY	PART NUMBER	DESCRIPTION
1	1	PU-05011-120	PISTON SHAFT; SIZE 120
2	1	PU-05041	PISTON BEARING, 120
3	1	PU-01016A-012	PISTON SEAL; SIZE 120
4	1	PU-05030	120 SNAP RING
5	1	PU-05031	PISTON CLEVIS
6	1	PU-05029	120 SPRING PIN

80 PUMP PISTON ASSEMBLY			
ITEM	QTY	PART NUMBER	DESCRIPTION
1	1	PU-05011-80	PISTON SHAFT; SIZE 80
2	1	PU-05042	PISTON BEARING, 80
3	1	PU-01016A-008	PISTON SEAL; SIZE 80
4	1	PU-05030-80	80 SNAP RING
5	1	PU-05031	PISTON CLEVIS
6	1	PU-05029-80	80 SPRING PIN

60 PUMP PISTON ASSEMBLY			
ITEM	QTY	PART NUMBER	DESCRIPTION
1	1	PU-05011-60	PISTON SHAFT; SIZE 60
2	1	PU-05043	PISTON BEARING, 60
3	1	PU-01016A-006	PISTON SEAL; SIZE 60
4	1	PU-05030-60	60 SNAP RING
5	1	PU-05031	PISTON CLEVIS
6	1	PU-05029-60	60 SPRING PIN

40 PUMP PISTON ASSEMBLY			
ITEM	QTY	PART NUMBER	DESCRIPTION
1	1	PU-05011-40	PISTON SHAFT; SIZE 40
2	1	PU-05044	PISTON BEARING, 40
3	1	PU-01016A-004	PISTON SEAL; SIZE 40
4	1	PU-05030-40	40 SNAP RING
5	1	PU-05031	PISTON CLEVIS
6	1	PU-05029-40	40 SPRING PIN

MANUAL REVISIONS

Revision	Date	Changes	Approved
1.0	01NOV2015	Initial release of Pump Rebuild Instructions	Vadams
2.0	01JAN2016	Updated Pump Rebuild Kits Added 60 and 40 size pumps	ScottS
2.1	01-Apr-2016	Added RA-00065A to A Side Pump Rebuild Kits	
2.2	18-May-2018	Page 12, added Pump Base Assembly instruction.	BrendanB
2.3	July 7, 2021	Added new style split sleeve rebuild instructions	JasonE